

Advance Optima AO2000 Series Continuous gas analyzers Models AO2020, AO2040

Measurement made easy

Modular continuous gas
analyzers



One central unit and various analyzer modules

Common controls, common connection technology,
common system housing

Analyzer modules with different measurement principles
for all process and emissions monitoring applications

Multiple analyzer systems with up to four analyzer
modules handling a total of six sample components

Extensive automatic calibration with air or integral
calibration cells eliminating the need for test gas cylinders

“Safety Concept” for measuring flammable gases in
Zone 2 and for measuring corrosive and toxic gases

Simultaneous digital and analog display of measured
values on a large graphics panel

Menu-driven operator interface

Clear-text status messages

Multiple interfaces for communication with host and
associated systems

Flexibly configurable analog and digital inputs and
outputs on various input/output modules

Optional integrated pneumatics module

Housing design for 19-inch rack mounting
(Model AO2020) or wall mounting (Model AO2040)

Modular design for ease of service

Self-monitoring function indicates when maintenance is
required

Modular analyzer product line

Overview

Advance Optima AO2000 Series is a line of modules used for continuous process gas analysis.

The product line consists of the following modules:

- Analyzer modules
- Pneumatics module
- Electronics module with system controller and I/O modules
- Housing with display and control unit
- System bus

The modules can be arranged in various ways to form single or multiple analyzer systems.

The electronics module, power supply and housing with display and control unit are also collectively referred to as the “central unit”.

Analyzer modules

Analyzer modules:

- Uras26 Infrared analyzer module
- Limas21 UV Process photometer analyzer module
- Limas21 HW Process photometer analyzer module
- Limas11 IR Process photometer analyzer module
- Magnos206 Oxygen analyzer module
- Magnos27 Oxygen analyzer module
- ZO23 Trace oxygen analyzer module
- Caldos25 Thermal conductivity analyzer module
- Caldos27 Thermal conductivity analyzer module
- Fidas24 FID analyzer module
- Fidas24 NMHC FID analyzer module
- LS25 Laser analyzer module

Each analyzer module consists of the sensor and associated electronics having its own processor. The analyzer modules are linked to the system controller via the system bus. The laser analyzer module is linked to the central unit via Ethernet.

The analyzer modules are supplied with 24-VDC from an integral power supply or an external unit.

The electrochemical oxygen sensor is available as an option in combination with an analyzer module.

Pneumatics module

The pneumatics module contains the following elements when fully equipped:

- One or three solenoids to control test gas supply
- One or two disposable elements for fine filtration
- One gas supply pump with coarse filter and capillary
- One or two flow monitors

The pneumatics module is always associated with an analyzer module and installed in the same housing as the analyzer module.

Electronics module, interfaces

The electronics module incorporates the system controller with the I/O modules.

The **system controller** carries out the following functions:

- Processing and communicating the measured values supplied by the analyzer module sensor electronics
- Compensating measured values, e.g. cross sensitivity correction

- Controlling system functions, e.g. calibration
- Display and control functions
- Controlling associated systems, e.g. gas supply
- Communicating with external systems

The system controller communicates with the other functional units of the gas analyzer (e.g. the analyzer modules) via the system bus.

Interfaces for controlling associated systems and for communicating with external systems are located on the system controller (Ethernet 10/100/1000BASE-T interface) and on the I/O modules.

The **I/O modules** are attached and directly connected to the system controller board. There are six types of I/O modules:

- Profibus modules have one RS485 and one MBP interface.
- Modbus modules have one RS485 and one RS232 interface.
- Digital I/O modules have four digital inputs and four digital outputs.
- 2-way analog output modules have two analog outputs.
- 4-way analog output modules have four analog outputs.
- 4-way analog input modules have four analog inputs.

Examples of I/O module applications include:

- Output of measured values
- Output of status and alarm signals
- Calibration control
- Control of external solenoid valves and pumps
- Measurement range switching and feedback
- Feed of current or status signals from external analyzers
- Feed of status signals from peripherals

Housing

The housing is available as a 19-inch (model AO2020) or wall-mount (model AO2040) unit with IP20 or IP54 protection. IP54 housing versions can be purged. The display and control unit is located on the front panel of the housing when the electronics module is installed.

System bus

The gas analyzer's functional units are interconnected via the system bus. The system bus structure is linear with a maximum length of 350 meters. Only one electronics module with up to five I/O modules should be connected to a system bus structure.

Connection of sample gas conditioning modules

The SCC-F sample gas feed unit and the SCC-C sample gas cooler can be connected to the gas analyzer via the system bus by means of an I/O board installed in the sample gas feed unit. Thus it is possible to display, monitor and control individual sample gas conditioning functions in the gas analyzer such as cooler temperature or condensate and flow status. For further information please refer to the “System components and accessories for sample gas conditioning” data sheet.

Configuration of analyzer units and multiple analyzer systems

This data sheet contains specifications for all modules and components in the Advance Optima AO2000 Series modular product line.

This data sheet was not intended to be used for configuring an analyzer unit or a multiple analyzer system. For a quotation please contact your ABB Analytical representative who can also provide advice and support.

Example 1 shows the modules and components that normally make up an analyzer unit as well as the possibilities for configuring an analyzer unit.

The modular product line allows modules and components to be formed into an analyzer unit (see example 1) or into multiple analyzer systems (see example 2).

Example 1: Analyzer unit configuration (19-inch housing)

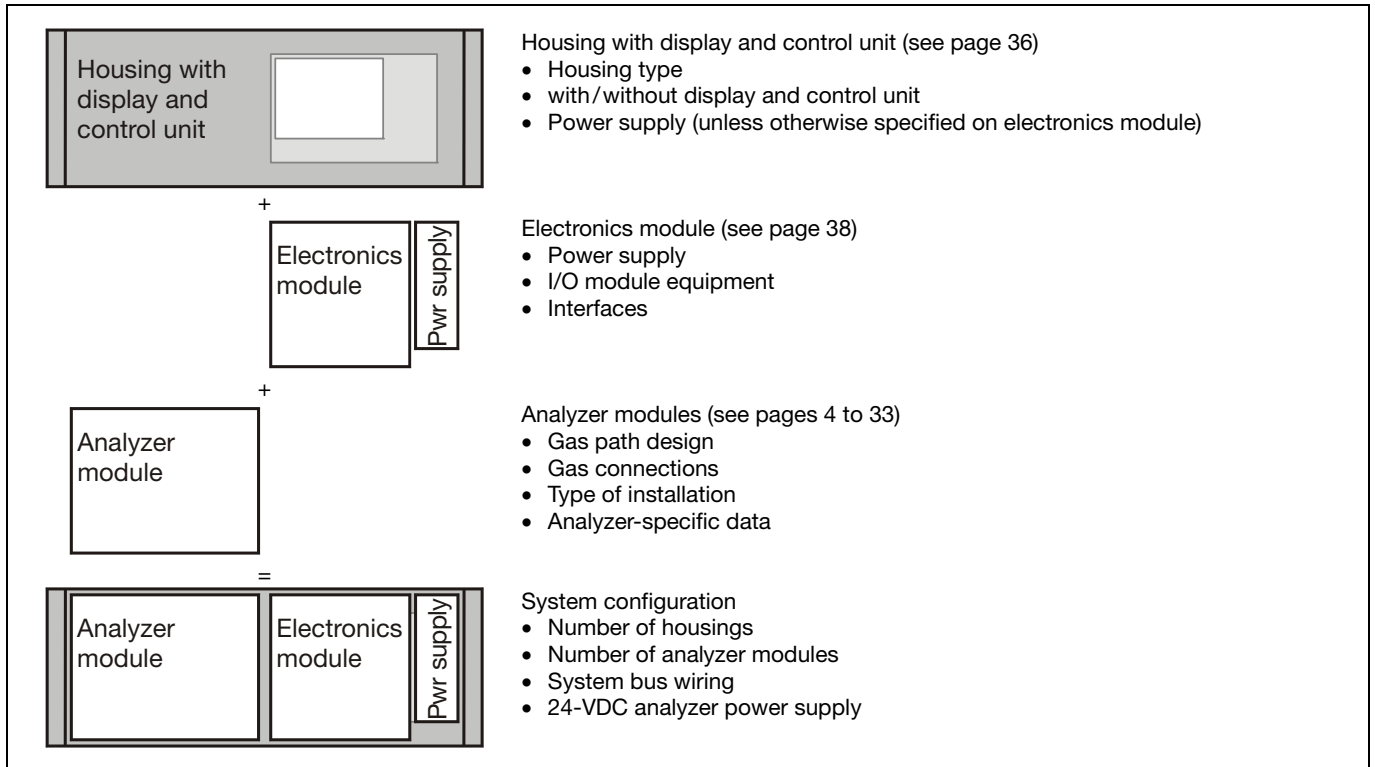

Example 2: Multiple analyzer system variant (wall-mount housings)

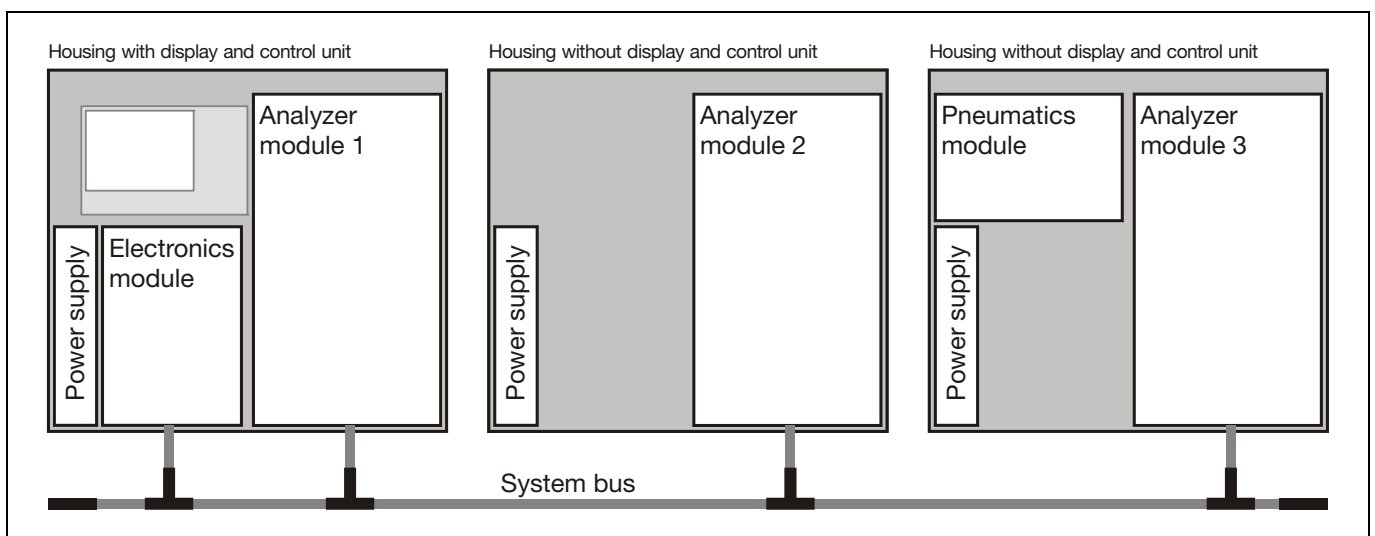

Infrared analyzer module Uras26

Measurement principle

Non-dispersive infrared absorption in the $\lambda = 2.5$ to $8 \mu\text{m}$ wavelength range

Photometer to measure from 1 to 4 components with 1 or 2 beam paths and 1 or 2 receivers in each beam path

Sample components and measurement ranges

The Uras26 analyzer module has one physical measurement range per sample component. As an option, smaller measurement ranges can be electronically derived from the physical measurement range. The smallest range is measurement range 1.

The smallest measurement ranges shown in the following table are based on the first sample component in beam path 1.

Sample component	Smallest class 1 range	Smallest class 2 range	Smallest class 2 range with calibration cell	Gas group ¹⁾
CO	0– 50 ppm	0– 10 ppm	0– 50 ppm ²⁾	A
CO ₂	0– 50 ppm	0– 5 ppm	0– 25 ppm ²⁾	A
NO	0– 75 ppm	0– 75 ppm	0– 75 ppm ²⁾	A
SO ₂	0– 100 ppm	0– 25 ppm	0– 25 ppm ²⁾	A
N ₂ O	0– 50 ppm	0– 20 ppm	0– 50 ppm ²⁾	A
CH ₄	0– 100 ppm	0– 50 ppm	0– 50 ppm ²⁾	A
NH ₃	0– 500 ppm	0– 30 ppm	–	B
C ₂ H ₂	0– 200 ppm	0– 100 ppm	0– 100 ppm	B
C ₂ H ₄	0– 500 ppm	0– 300 ppm	0– 300 ppm	B
C ₂ H ₆	0– 100 ppm	0– 50 ppm	0– 50 ppm ²⁾	B
C ₃ H ₆	0– 250 ppm	0– 100 ppm	0– 100 ppm ²⁾	B
C ₃ H ₈	0– 100 ppm	0– 50 ppm	0– 50 ppm ²⁾	B
C ₄ H ₁₀	0– 100 ppm	0– 50 ppm	0– 50 ppm ²⁾	B
C ₆ H ₁₄	0– 500 ppm	0– 100 ppm	0– 100 ppm ²⁾	B
R 134a	0– 100 ppm	0– 50 ppm	0– 50 ppm ²⁾	B
SF ₆	0– 5 ppm	0– 4 ppm	–	B
H ₂ O	0– 1000 ppm	0– 500 ppm	0– 500 ppm	C

1) See price information

2) The smallest measurement range 1 is shown. The largest measurement range should be at least four times larger.

Other sample components on request.

Measurement range quantity

1 to 4 ranges per sample component

Largest measurement range

0 to 100 vol.% or 0 vol.% to saturation or 0 vol.% to LEL

Measurement ranges within ignition limits cannot be provided.

Measurement range ratio

≤ 1:20

Measurement ranges with suppressed zero-point

Electronic zero-point suppression or differential measurement based on a base level > 0 with flowing reference gas, max. suppression ratio of 1:10

Stability

The following data apply only if all influence factors (e.g. flow rate, temperature, atmospheric pressure) are constant. They apply to measurement range 1 in a delivered analyzer module.

Linearity deviation

≤ 1 % of span

Option: Linearization according to EPA specifications for automobile exhaust gas measurement

Repeatability

≤ 0.5 % of span

Zero drift

≤ 1 % of span per week;

for ranges smaller than class 1 to class 2:

≤ 3 % of span per week

Sensitivity drift

≤ 1 % of measured value per week

Output fluctuation (2 σ)

≤ 0.2 % of span at electronic T90 time = 5 sec (class 1) or

= 15 sec (class 2)

Detection limit (4 σ)

≤ 0.4 % of span at electronic T90 time = 5 sec (class 1) or

= 15 sec (class 2)

Influence effects

Flow effect

Flow rate in the 20 to 100 l/h range: Within detection limits

Associated gas effect/cross sensitivity

The knowledge of the sample gas composition is necessary for the analyzer configuration.

Selectivity measures to reduce associated gas effect

(optional): Incorporation of interference filters or filter vessels, internal electronic cross-sensitivity correction or carrier gas correction for a sample component by other sample components measured with the Uras26.

Temperature effect

Ambient temperature in permissible range

– At zero-point: ≤ 1 % of span per 10 °C;
for ranges smaller than class 1 to class 2:
≤ 2 % of span per 10 °C

– On sensitivity with temperature compensation:
≤ 3 % of measured value per 10 °C

– On sensitivity with thermostat effect at 55 °C (optional):
≤ 1 % of measured value per 10 °C

Air pressure effect

– At zero-point: No effect

– On sensitivity with pressure correction by means of integral pressure sensor: ≤ 0.2 % of measured value per 1 % air pressure change

The pressure sensor is located in the sample gas path if hoses are used as the internal gas lines.

If tubing is used for internal gas lines the pressure sensor is routed to the outside via a hose.

Pressure sensor working range: $p_{\text{abs}} = 600$ to 1250 hPa

Power supply effect

24 VDC ± 5 %: ≤ 0.2 % of span

Infrared analyzer module Uras26

Dynamic response

Warm-up time

Approx. 30 minutes without thermostat; approx. 2 hours with thermostat

90% response time

$T_{90} = 2.5$ sec for measurement cell length = 200 mm and sample gas flow = 60 l/h without signal damping (low pass filter). Low-pass time constant adjustable from 0 to 60 sec.

Calibration

Zero-point calibration

With inert gas, e.g. nitrogen, or with ambient air that is free of the sample component.

End-point calibration

With gas-filled calibration cells (optional) or with test gas mixtures. It is recommended to verify the calibration cell set values once a year.

During calibration of a multi-component analyzer, possible cross-sensitivity and/or carrier gas corrections by internal or external measurement components are switched off.

Therefore, corrected measurement components should be calibrated only using a test gas consisting of the measurement component and an inert gas like nitrogen.

Materials in contact with the sample medium

Analyzer (sample cells)

Tubing: Aluminum or gold-plated aluminum. Window: CaF_2 , option: BaF_2 . Connectors: Rust- and acid-resistant steel 1.4571 (SAE 316Ti).

Gas lines and connectors

FPM hoses and PTFE tubing with stainless steel connectors. Option: Rust- and acid-resistant steel tubes 1.4571 (SAE 316Ti).

Sample gas inlet conditions

Temperature

The sample gas dew point should be at least 5 °C below the ambient temperature throughout the sample gas path. Otherwise a sample gas cooler or condensate trap is required.

Pressure

The analyzer module is operated under atmospheric pressure; the sample gas outlet is open to atmosphere. Internal pressure drop < 5 hPa with standard flow rate 60 l/h. Permissible absolute pressure range: 800 to 1250 hPa. Operation under lower absolute pressure (e.g. at altitudes above 2000 m) on request. Overpressure in the sample cell max. 500 hPa.

Flow rate

20 to 100 l/h

Corrosive gases

Highly corrosive associated gas components, e.g. chlorine (Cl_2) and hydrogen chloride (HCl), as well as gases or aerosols containing chlorine must be cooled or undergo prior absorption. Provide for housing purge.

Flammable gases

The analyzer module is suitable for measuring flammable gases and vapors under atmospheric conditions ($p_{\text{abs}} \leq 1.1$ bar, oxygen content ≤ 21 vol.%). Temperature class: T4. The sample gas must not be explosive under normal conditions.

If the sample gas is explosive in the event of a sample gas supply failure, then only seldom and briefly (in accordance with zone 2). Pressure in the sample gas path in normal operation $p_e \leq 100$ hPa; in case of a sample gas supply failure the pressure must not exceed the maximum value $p_e = 500$ hPa. The version with gas paths designed as stainless steel tubes should be selected and housing purge with nitrogen should be provided when measuring flammable gases and vapors. Before using the analyzer module the corrosion resistance against the specific sample gas must be checked.

Version in category 3G see page 34

Gas connections

The drawing below shows the gas connection arrangement in an exemplary manner for the three variants:

A 1 gas path with 1 sample cell,

B 1 gas path with 2 sample cells in series and

C 2 separate gas paths with 1 sample cell each.

The actual gas connection arrangement of an analyzer module is found in the analyzer data sheet for the delivered instrument.

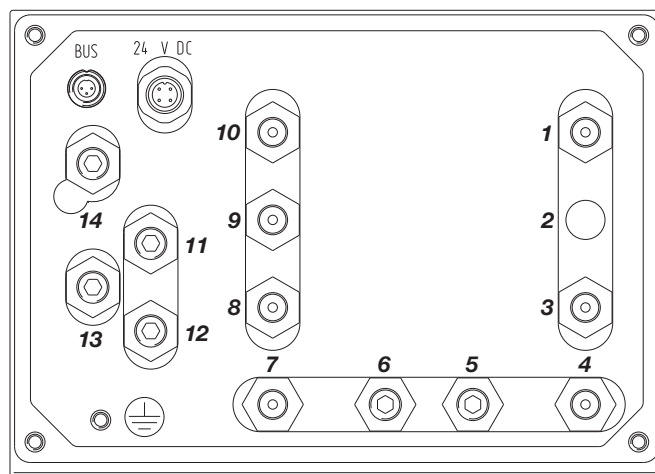

- 1 Pressure sensor for external pressure measurement ¹⁾
 - 2 –
 - 3 Sample gas inlet **A** or **B** or **C** gas path 1
 - 4 Sample gas outlet **A** or **C** gas path 1
 - 5 Purge gas inlet housing ¹⁾
 - 6 Purge gas outlet housing ¹⁾ (also with flow sensor)
 - 7 Sample gas inlet **C** gas path 2 ¹⁾
 - 8 Sample gas outlet **B** or **C** gas path 2 ¹⁾
 - 9 Reference gas inlet gas path 1 ¹⁾
 - 10 Reference gas outlet gas path 1 ¹⁾
Pneumatics module ¹⁾;
 - 11 Sample gas inlet **A** or **B** or **C** gas path 1
 - 12 End point gas inlet (with 3 solenoids)
or sample gas inlet **C** gas path 2 (only with flow sensor)
 - 13 Test gas/zero-point gas inlet (with 1 or 3 solenoids)
or sample gas outlet **C** gas path 2 (only with flow sensor) – in this case connect with sample gas inlet **7**
 - 14 Sample gas outlet **A** or **B** or **C** gas path 1 – connect with sample gas inlet **3**
- 1) Option

Process photometer analyzer module Limas21 UV

Measurement principle and application

Gas filter correlation or wavelength comparison in ultraviolet and visible spectrum range $\lambda = 200$ to 600 nm

Photometer to measure from 1 to 4 components

Sample cells made from various materials are available for measuring in corrosive, toxic and flammable gases (see page 12)

Sample components and measurement ranges

The Limas21 UV analyzer module has one physical measurement range per sample component. As an option, smaller measurement ranges can be electronically derived from the physical measurement range. The smallest range is measurement range 1.

Sample component	Smallest class 1 range	Smallest class 2 range	Gas group ¹⁾
NO ²⁾	0– 50 ppm	0– 10 ppm	A
SO ₂	0– 150 ppm	0– 25 ppm	A
NO ₂	0– 250 ppm	0– 50 ppm	B
NH ₃	0– 100 ppm	0– 30 ppm	B
H ₂ S	0– 50 ppm	0– 25 ppm	B
Cl ₂	0– 250 ppm	0– 100 ppm	D
CS ₂	0– 100 ppm	0– 50 ppm	C
COS	0– 500 ppm	0– 250 ppm	C

1) See price information

2) The UV-RAS (ultra-violet resonant absorption spectroscopy) method is used to make the analyzer selective to the sample component NO.

Other sample components on request.

Measurement range quantity

1 to 4 ranges per sample component

Largest measurement range

0 to 100 vol.% or 0 vol.% to saturation or 0 vol.% to LEL
Measurement ranges within ignition limits cannot be provided.

Measurement range ratio

Measurement ranges freely adjustable within a range ratio of 1:20 relative to the factory-set reference measurement range.

Measurement ranges with suppressed zero-point

Electronic zero-point suppression, max. suppression ratio of 1:10

Stability

The following data apply only if all influence factors (e.g. flow rate, temperature, atmospheric pressure) are constant. They apply to measurement range 1 in a delivered analyzer module.

Linearity deviation

≤ 1 % of span

Option: Linearization acc. to EPA specifications for automotive exhaust gas measurement

Repeatability

≤ 0.5 % of span

Zero drift

≤ 2 % of span per week;

for ranges smaller than class 1 to class 2: ≤ 1.5 % of span per day (Recommendation: daily automatic zero-point calibration)

Sensitivity drift

≤ 1 % of measured value per week

Output fluctuation (2 σ)

≤ 0.5 % of span at electronic T90 time = 10 sec;

for ranges smaller than class 1 to class 2: ≤ 1 % of span

Detection limit (4 σ)

≤ 1 % of span;

for ranges smaller than class 1 to class 2: ≤ 2 % of span

Influence effects

Flow effect

Flow rate in the 20 to 100 l/h range: Within detection limits

Associated gas effect/cross sensitivity

The knowledge of the sample gas composition is necessary for the analyzer configuration.

Selectivity measures to reduce associated gas effect

(optional): Incorporation of filters cells or internal electronic cross-sensitivity correction or carrier gas correction for a sample component by other sample components measured with the Limas21 UV.

Temperature effect

Ambient temperature in permissible range,

Sample cell thermostat control to +60 °C

– At zero-point: ≤ 1 % of span per 10 °C; for ranges smaller than class 1 to class 2: ≤ 2 % of span per 10 °C

– On sensitivity: ≤ 1 % of measured value per 10 °C

Air pressure effect

– At zero-point: No effect

– On sensitivity with pressure correction by means of integral pressure sensor: ≤ 0.2 % of measured value per 1 % air pressure change

The pressure sensor is located in the sample gas path if hoses are used as the internal gas lines.

If tubing is used for internal gas lines the pressure sensor is routed to the outside via a hose.

Pressure sensor working range: $p_{abs} = 600$ to 1250 hPa

Power supply effect

24 VDC ± 5 %: ≤ 0.2 % of span

Process photometer analyzer module Limas21 UV

Dynamic response

Warm-up time

Approx. 2.5 hours

90% response time

T_{90} = 4 sec for measurement cell length = 262 mm and sample gas flow = 60 l/h without signal damping (low pass filter).

Low-pass time constant adjustable from 0 to 60 sec

Calibration

Zero-point calibration

With inert gas, e.g. nitrogen, or with ambient air that is free of the sample component

End-point calibration

With gas-filled calibration cells (optional) or with test gas.

It is recommended to verify the calibration cell set values once a year.

During calibration of a multi-component analyzer, possible cross-sensitivity and/or carrier gas corrections by internal or external measurement components are switched off.

Therefore, corrected measurement components should be calibrated only using a test gas consisting of the measurement component and an inert gas like nitrogen.

Materials in contact with the sample medium

See page 12

Sample gas inlet conditions

Temperature

The sample gas dew point should be at least 5 °C below the ambient temperature throughout the sample gas path. Otherwise a sample gas cooler or condensate trap is required.

Pressure

The analyzer module is operated under atmospheric pressure; the sample gas outlet is open to atmosphere. Internal pressure drop < 5 hPa with standard flow rate 60 l/h. Permissible absolute pressure range: 800 to 1250 hPa. Operation under lower absolute pressure (e.g. at altitudes above 2000 m) on request. Overpressure in the sample cell max. 500 hPa.

Flow rate

20 to 100 l/h

Corrosive, toxic and flammable gases

See page 12

Purge gas

See page 12

Gas connections

See page 13

Process photometer analyzer module Limas21 HW

Measurement principle and application

Limas21 HW is a multi-component analyzer for simultaneous measurement of nitrogen compounds in wet sulfur-free flue gas without converter.

Measurement principle

Photometer to measure NO, NO₂ and NH₃.

The UV-RAS method (ultra-violet resonant absorption spectroscopy) is used to make the analyzer selective to the sample component NO.

Wavelength comparison in ultraviolet spectrum range $\lambda = 200$ to 600 nm.

Applications

Exhaust gas measurement for the development of combustion engines and methods for exhaust gas after-treatment, in particular for pure gas measurement after catalyst in

- Four-stroke gasoline and diesel engines,
- Catalysts for nitrogen oxide reduction.

Process measurement e.g. for monitoring, controlling and optimizing DeNO_x SCR processes.

Sample components and measurement ranges (recommendations), stability data

Exhaust gas measurement for four-stroke gasoline and diesel engines

Sample component	Smallest range	Largest range
NO	0–100 ppm	0–5000 ppm
NO ₂	0–100 ppm	0–2500 ppm

Linearity deviation

≤ 1 % of span, ≤ 2 % of measured value acc. to EPA specifications for automotive exhaust gas measurement

Repeatability

≤ 0.25 % of span

Zero drift

≤ 1 ppm or ≤ 1 % of span per 24 hours based on the smallest recommended measurement range (daily automatic zero-point calibration recommended)

Sensitivity drift

≤ 1 % of measured value per week

Output fluctuation (2 σ)

≤ 400 ppb or ≤ 0.4 % of span at electronic T90 time = 5 sec

Detection limit (4 σ)

≤ 800 ppb or ≤ 0.8 % of span at electronic T90 time = 5 sec

Diluted exhaust gas measurement for four-stroke gasoline and diesel engines, bag measurement

Sample component	Smallest range	Largest range
NO	0–10 ppm	0–500 ppm
NO ₂	0–10 ppm	0–500 ppm

Linearity deviation

≤ 1 % of span, ≤ 2 % of measured value acc. to EPA specifications for automotive exhaust gas measurement

Repeatability

≤ 0.25 % of span

Zero drift

≤ 250 ppb or ≤ 2 % of span per 8 hours based on the smallest recommended measurement range (daily automatic zero-point calibration recommended)

Sensitivity drift

≤ 1 % of measured value per week

Output fluctuation (2 σ)

NO ≤ 50 ppb or ≤ 0.5 % of span, NO₂ ≤ 60 ppb or ≤ 0.5 % of span at electronic T90 time = 15 sec

Detection limit (4 σ)

NO ≤ 100 ppb or ≤ 1 % of span, NO₂ ≤ 120 ppb or ≤ 1 % of span at electronic T90 time = 15 sec

Process measurement

Sample Component	Smallest Range	Largest Range
NO	0–100 ppm	0–1000 ppm
NO ₂	0–100 ppm	0– 500 ppm
NH ₃	0–100 ppm	0– 500 ppm

Linearity deviation

≤ 1 % of span

Repeatability

≤ 0.25 % of span

Zero drift

≤ 1 ppm or ≤ 1 % of span per 24 hours based on the smallest recommended measurement range (daily automatic zero-point calibration recommended)

Sensitivity drift

≤ 1 % of measured value per week

Output fluctuation (2 σ)

≤ 150 ppb or ≤ 0.15 % of span at electronic T90 time = 30 sec

Detection limit (4 σ)

≤ 300 ppb or ≤ 0.3 % of span at electronic T90 time = 30 sec

Measurement ranges

Quantity

1 to 4 ranges per sample component

Measurement range ratio

Max. 1:20. Measurement ranges are freely adjustable within a range ratio of 1:20 relative to the factory-set reference measurement range.

Max. 1:50 for fixed measurement ranges acc. to EPA specifications for automotive exhaust gas measurement.

Influence effects

Flow effect

Flow rate in the 20 to 90 l/h range: within detection limits

Associated gas effect/cross sensitivity

The knowledge of the sample gas composition is necessary for the analyzer configuration.

Selectivity measures to reduce associated gas effect: Internal electronic cross-sensitivity correction or carrier gas correction for a sample component by other sample components measured with the Limas21 HW.

Temperature effect

Ambient temperature in permissible range,
Sample cell thermostat control to +82 °C

- At zero-point: $\leq 2\%$ of span per 10 °C
- On sensitivity: $\leq 2\%$ of measured value per 10 °C

Air pressure effect

- At zero-point: No effect
- On sensitivity with pressure correction by means of integral pressure sensor: $\leq 0.2\%$ of measured value per 1% air pressure change

The pressure sensor is routed to the outside via a hose.
Pressure sensor working range: $p_{\text{abs}} = 600$ to 1250 hPa

Power supply effect

24 VDC $\pm 5\%$: $\leq 0.2\%$ of span

Dynamic response

Warm-up time

Approx. 4 hours

90% response time

$T_{90} \leq 5$ sec for measurement cell length = 260 mm and sample gas flow = 60 l/h with non-linear filter (static/dynamic) = 15/1 sec.

Low-pass time constant adjustable from 0 to 30 sec.

Calibration

Zero-point calibration

With inert gas, e.g. nitrogen, or with ambient air that is free of the sample component

End-point calibration

With gas-filled calibration cells (optional) or with test gas.

It is recommended to verify the calibration cell set values once a year.

During calibration of a multi-component analyzer, possible cross-sensitivity and/or carrier gas corrections by internal or external measurement components are switched off.

Therefore, corrected measurement components should be calibrated only using a test gas consisting of the measurement component and an inert gas like nitrogen.

Materials in contact with the sample medium

Sample cell

Tubing and window: Silica glass, Screw connection: PVDF;
Connectors: PTFE

Gas lines and connectors

Stainless steel 1.4305 (SAE 303), 1.4571 (SAE 316Ti)

Housing purge

Purge gas

Sample component-free air or nitrogen
Purge gas flow rate ≤ 10 l/h

Sample gas inlet conditions

Sample gas composition

Sulfur-free exhaust gas of combustors,
 SO_2 concentration < 25 ppm, $\text{H}_2\text{O} < 20$ vol.%,
filtered with pore width ≤ 0.5 μm

Temperature

Sample gas dew point ≤ 60 °C

Pressure

The analyzer module is operated under atmospheric pressure; the sample gas outlet is open to atmosphere. Internal pressure drop < 5 hPa with standard flow rate 60 l/h. Permissible absolute pressure range: 800 to 1250 hPa. Operation under lower absolute pressure (e.g. at altitudes above 2000 m) on request. Overpressure in the sample cell max. 500 hPa.

Flow rate

20 to 90 l/h

Gas connections

See page 13

Notes

The analyzer module Limas21 HW can only be mounted in the 19-inch housing.

SO_2 influences the NH_3 reading. If the sample gas mixture contains SO_2 , the requirement of internal corrections must be scrutinized.

When ordering the average water vapor concentration has to be specified. The influence is corrected internally.

Sample conditioning system requirements

Sample gas feed-in

The various applications require the sample gas feed-in to the gas analyzer at temperatures of 150 to 190 °C. It is imperative to eliminate condensation and sublimation since NH_3 and NO_2 are easy soluble in water and can result in salification. It is also imperative to prevent condensation of potentially present low-boiling hydrocarbons.

Sample gas inlet temperature (on the process side)

150 to 190 °C

Sample gas filter

For NO and NO_2 measurement: Sintered metal; for NH_3 measurement: Ceramics; pore width ≤ 0.5 μm

Materials in contact with the sample medium

PTFE, PVDF or Silicosteel

Exhaust gas conditions

Outlet pressure = atmospheric pressure, no resistance in the gas outlet.

Installation note

Route the exhaust gas line declining to allow for condensate drain-off.

Process photometer analyzer module Limas11 IR

Measurement principle and application

Gas filter correlation or wavelength comparison in infrared spectrum range $\lambda = 2.5$ to $10 \mu\text{m}$

Photometer to measure from 1 to 4 components

Sample cells made from various materials are available for measuring in corrosive, toxic and flammable gases (see page 12)

Sample components and measurement ranges

The Limas11 IR analyzer module has one physical measurement range per sample component. As an option, smaller measurement ranges can be electronically derived from the physical measurement range. The smallest range is measurement range 1.

Sample component	Smallest class 1 range	Smallest class 2 range	Gas group ¹⁾
CO	0–1000 ppm	0– 500 ppm	A
CO ₂	0– 300 ppm	0– 150 ppm	A
HCl	0–5000 ppm	0–2500 ppm	D
CH ₄	0–2000 ppm	0–1000 ppm	A
C ₂ H ₂	0–2500 ppm	0–1250 ppm	B
C ₂ H ₄	0–3000 ppm	0–1500 ppm	B
C ₂ H ₆	0– 500 ppm	0– 250 ppm	B
C ₃ H ₆	0–1000 ppm	0– 500 ppm	B
C ₃ H ₈	0– 300 ppm	0– 150 ppm	B
C ₄ H ₁₀	0– 500 ppm	0– 250 ppm	B

1) See price information

Other sample components on request.

Measurement range quantity

1 to 4 ranges per sample component

Largest measurement range

0 to 100 vol.% or 0 vol.% to saturation or 0 vol.% to LEL
Measurement ranges within ignition limits cannot be provided.

Measurement range ratio

Measurement ranges freely adjustable within a range ratio of 1:20 relative to the factory-set reference measurement range.

Measurement ranges with suppressed zero-point

Electronic zero-point suppression, max. suppression ratio of 1:10

Stability

The following data apply only if all influence factors (e.g. flow rate, temperature, atmospheric pressure) are constant. They apply to measurement range 1 in a delivered analyzer module.

Linearity deviation
 $\leq 1\%$ of span

Repeatability
 $\leq 0.5\%$ of span

Zero drift

$\leq 2\%$ of span per week;
for ranges smaller than class 1 to class 2: $\leq 1.5\%$ of span per day (Recommendation: daily automatic zero-point calibration)

Sensitivity drift

$\leq 1\%$ of measured value per week

Output fluctuation (2σ)

$\leq 0.5\%$ of span at electronic T90 time (static/dynamic) = 60/5 sec;
for ranges smaller than class 1 to class 2: $\leq 1\%$ of span

Detection limit (4σ)

$\leq 1\%$ of span;
for ranges smaller than class 1 to class 2: $\leq 2\%$ of span

Influence effects

Flow effect

Flow rate in the 20 to 100 l/h range: Within detection limits

Associated gas effect/cross sensitivity

The knowledge of the sample gas composition is necessary for the analyzer configuration.

Selectivity measures to reduce associated gas effect (optional): Incorporation of filters cells or internal electronic cross-sensitivity correction or carrier gas correction for a sample component by other sample components measured with the Limas11 IR.

Temperature effect

Ambient temperature in permissible range,

Sample cell thermostat control to $+60\text{ }^\circ\text{C}$

- At zero-point: $\leq 1\%$ of span per $10\text{ }^\circ\text{C}$; for ranges smaller than class 1 to class 2: $\leq 2\%$ of span per $10\text{ }^\circ\text{C}$
- On sensitivity: $\leq 1\%$ of measured value per $10\text{ }^\circ\text{C}$

Air pressure effect

- At zero-point: No effect
- On sensitivity with pressure correction by means of integral pressure sensor: $\leq 0.2\%$ of measured value per 1% air pressure change

The pressure sensor is located in the sample gas path if hoses are used as the internal gas lines.

If tubing is used for internal gas lines the pressure sensor is routed to the outside via a hose.

Pressure sensor working range: $p_{\text{abs}} = 600$ to 1250 hPa

Power supply effect

$24\text{ VDC} \pm 5\%$: $\leq 0.2\%$ of span

Process photometer analyzer module Limas11 IR

Dynamic response

Warm-up time

Approx. 2.5 hours

90% response time

T_{90} = 4 sec for measurement cell length = 262 mm and sample gas flow = 60 l/h without signal damping (low pass filter).

Low-pass time constant adjustable from 0 to 60 sec

Calibration

Zero-point calibration

With inert gas, e.g. nitrogen, or with ambient air that is free of the sample component

End-point calibration

With gas-filled calibration cells (optional) or with test gas.

It is recommended to verify the calibration cell set values once a year.

During calibration of a multi-component analyzer, possible cross-sensitivity and/or carrier gas corrections by internal or external measurement components are switched off.

Therefore, corrected measurement components should be calibrated only using a test gas consisting of the measurement component and an inert gas like nitrogen.

Materials in contact with the sample medium

See page 12

Sample gas inlet conditions

Temperature

The sample gas dew point should be at least 5 °C below the ambient temperature throughout the sample gas path. Otherwise a sample gas cooler or condensate trap is required.

Pressure

The analyzer module is operated under atmospheric pressure; the sample gas outlet is open to atmosphere. Internal pressure drop < 5 hPa with standard flow rate 60 l/h. Permissible absolute pressure range: 800 to 1250 hPa. Operation under lower absolute pressure (e.g. at altitudes above 2000 m) on request. Overpressure in the sample cell max. 500 hPa.

Flow rate

20 to 100 l/h

Corrosive, toxic and flammable gases

See page 12

Purge gas

See page 12

Gas connections

See page 13

Process photometer analyzer modules Limas21 UV, Limas21 HW, Limas11 IR

Sample cells

	Standard cell	Quartz cell	Safety cell
Application	Standard applications	Corrosive gases	Corrosive, toxic and flammable gases
Wavelength range	200 to 10000 nm	200 to 4000 nm	CaF ₂ window: 200 to 10000 nm SiO ₂ window: 200 to 4000 nm
Resistance ¹⁾			
Suitable for measurement of ...	Non-corrosive gases	Corrosive gases, e.g. wet Cl ₂ , wet HCl, H ₂ SO ₄ , SO ₃ , ozone	Corrosive gases, e.g. dry HCl, dry COCl ₂ (< 50 ppm H ₂ O)
Not suitable for measurement of ...	Highly corrosive gases, e.g. gases containing chlorine, H ₂ SO ₄ , SO ₃ , fluorine compounds	Fluorine compounds	Wet gases containing chlorine, H ₂ SO ₄ , SO ₃ , fluorine compounds
Safety principle			
Toxic gases	Housing purge (≤ 20 l/h) with sample component-free air or with N ₂	Housing purge (≤ 20 l/h) with sample component-free air or with N ₂	Cell purge ²⁾ with N ₂ or with sample component-free air with negative pressure and flow monitoring; additional monitoring for sample gas traces possible
Corrosive gases	PTFE gas lines, housing purge (≤ 20 l/h) with sample component-free air or with N ₂	Housing purge (≤ 20 l/h) with sample component-free air or with N ₂	Cell purge ²⁾ with N ₂ or with sample component-free air with excess pressure ³⁾ and flow monitoring
Flammable gases ⁴⁾	Stainless steel gas lines, housing purge (≤ 20 l/h) with N ₂	Housing purge (≤ 20 l/h) with N ₂	Cell purge ²⁾ with N ₂
Seal integrity	< 1 x 10 ⁻³ hPa l/s	< 1 x 10 ⁻⁶ hPa l/s	< 1 x 10 ⁻⁶ hPa l/s
Pressure rating			
Continuous	p _e < 500 hPa	p _e < 500 hPa	p _e < 500 hPa
Spike	–	p _{abs} < 300 kPa	p _{abs} < 500 kPa
Sample cell material			
Cell tube	Aluminum	Silica glass (SiO ₂)	Stainless steel 1.4571 (SAE 316Ti)
Window	CaF ₂ , adhesive fastening	Silica glass	CaF ₂ or SiO ₂ , threaded fastening
Seal	–	FFKM75	FFKM70
Connectors	SS 1.4571 (SAE 316Ti)	PFA	SS 1.4571 (SAE 316Ti)
Gas line materials	FPM or PTFE	PFA	SS 1.4571 (SAE 316Ti)
Gas connector materials	SS 1.4571 (SAE 316Ti)	PFA	SS 1.4571 (SAE 316Ti)
Sample gas connection design (connection drawings see page 13)	Connectors with 1/8 NPT internal threads	Pipes 6/4 mm	Pipes with 4 mm outer diameter

1) see pages 7, 9, 11
“Sample gas inlet conditions”

2) purge curtain

3) p_e = 7 to 20 hPa, 15 to 20 l/h

4) The analyzer module is suitable for measuring flammable gases and vapors under atmospheric conditions (p_{abs} ≤ 1.1 bar, oxygen content ≤ 21 vol. %). Temperature class: T4. The sample gas must not be explosive under normal conditions. If the sample gas is explosive in the event of a sample gas supply failure, then only seldom and briefly (in accordance with zone 2). Pressure in the sample gas path in normal operation p_e ≤ 100 hPa; in case of a sample gas supply failure the pressure must not exceed the maximum value p_e = 500 hPa. Before using the analyzer module the corrosion resistance against the specific sample gas must be checked.

Process photometer analyzer modules Limas21 UV, Limas21 HW, Limas11 IR

Gas connections

Limas21 UV, Limas11 IR: Standard cell with FPM or PTFE hoses, quartz cell with FPM or PTFE hoses, center connection cell made of aluminum or quartz

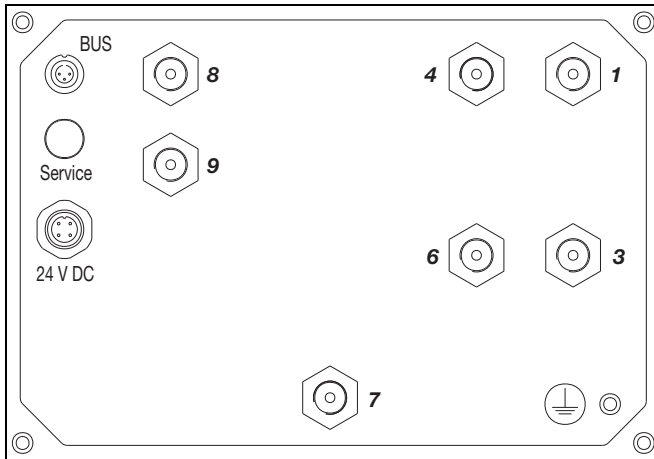

- 1 Sample gas inlet
- 3 Purge gas inlet housing ¹⁾
- 4 Sample gas outlet
- 6 Purge gas outlet housing ¹⁾
- 7 Pressure sensor ²⁾
- 8 End-point gas inlet (with 3 solenoids) ^{1) 3)}
- 9 Zero-point gas inlet (with 1 or 3 solenoids) ^{1) 3)}

1) Option
 2) external connection, not for standard cell with FPM hoses
 3) not for version with PTFE hoses

Limas21 UV, Limas11 IR: Quartz cell with PFA tubes

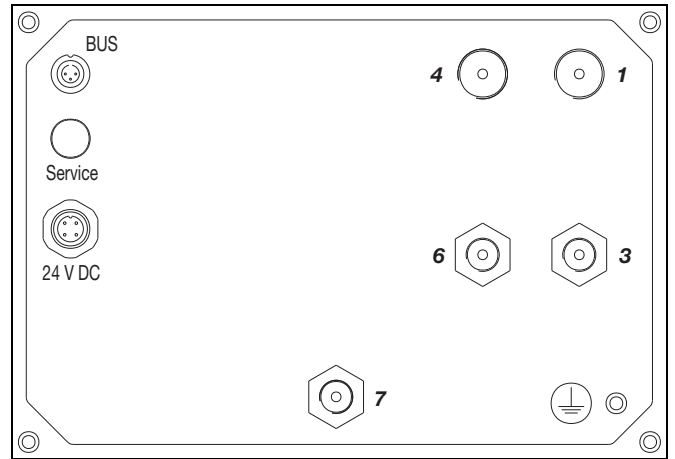

- 1 Sample gas inlet
 - 3 Purge gas inlet housing ¹⁾
 - 4 Sample gas outlet
 - 6 Purge gas outlet housing ¹⁾
 - 7 Pressure sensor
- 1) Option

Limas21 UV, Limas11 IR: Safety cell

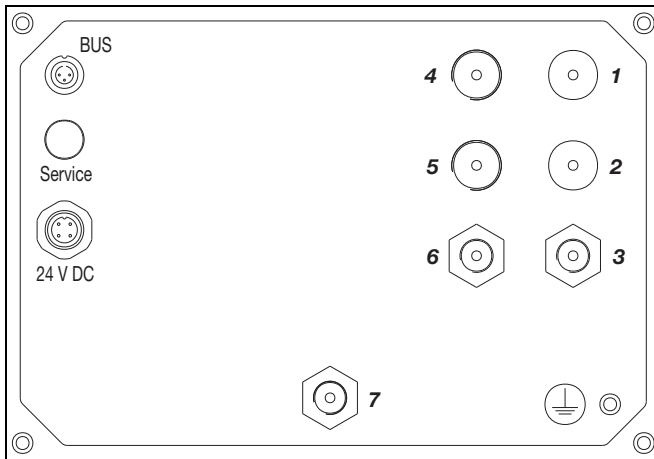

- 1 Sample gas inlet
- 2 Sample gas outlet
- 3 Purge gas inlet housing ¹⁾
- 4 Purge gas inlet sample cell
- 5 Purge gas outlet sample cell
- 6 Purge gas outlet housing ¹⁾
- 7 Pressure sensor

1) Option

Limas21 HW

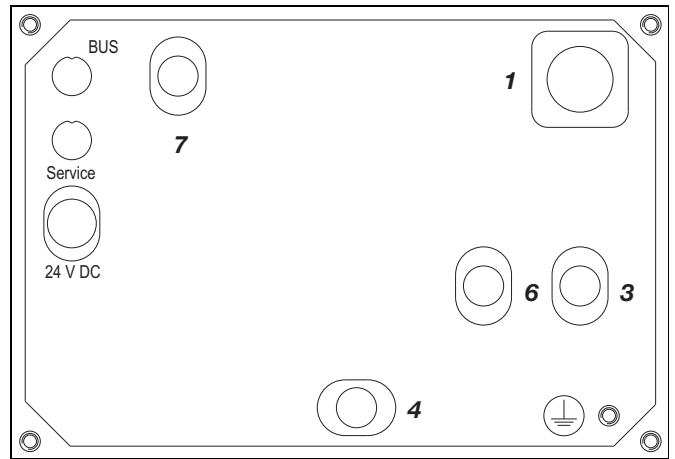

- 1 Sample gas inlet
- 3 Purge gas inlet housing
- 4 Sample gas outlet
- 6 Purge gas outlet housing
- 7 Pressure sensor

Measurement principle

Paramagnetic behavior of oxygen

Magnetomechanical analyzer

Sample component and measurement ranges

Sample component

Oxygen (O₂)

Smallest measurement range

0 to 0.5 vol.% O₂

Measurement range quantity and limits

4 measurement ranges

Measurement ranges are freely adjustable; they are factory-set to 0 to 10/15/25/100 vol.% O₂ or per order.

Largest measurement range

0 to 100 vol.% O₂

Measurement ranges within ignition limits cannot be provided.

Measurement ranges with suppressed zero-point

Max. measurement range suppression 1: 100, e.g.

99 to 100 vol.% O₂. Highly suppressed measurement ranges

(≥95 to 100 vol.% O₂) and initial measurement ranges in the

same analyzer should be avoided. Pressure correction by

means of pressure sensor required.

Stability

Linearity deviation

≤ 0.5 % of span, minimum 0.005 vol.% O₂

Repeatability

≤ 50 ppm O₂ (time base for gas exchange ≥ 5 minutes)

Zero drift

≤ 3 % of span of the smallest measurement range (per order)

per week, minimum 300 ppm O₂ per week; following pro-

longed transport and storage time the drift can be higher

during the first weeks of operation.

Sensitivity drift

≤ 0.1 vol.% O₂ per week or ≤ 1 % of measured value per week (not cumulative), whichever is smaller.

≤ 0.25 % of measured value per year, minimum 0.05 vol.% O₂ per year

Output fluctuation (2 σ)

≤ 25 ppm O₂ at electronic T90 time (static/dynamic) = 3/0 sec

Detection limit (4 σ)

≤ 50 ppm O₂ at electronic T90 time (static/dynamic) = 3/0 sec

Influence effects

Flow effect

≤ 0.1 vol.% O₂ in permissible range

Associated gas effect

Data regarding the effect of associated gases can be found in IEC 61207-3:2002 "Gas analyzers – Expression of performance – Part 3: Paramagnetic oxygen analyzers".

Temperature effect

Ambient temperature in permissible range

– At zero-point: ≤ 0.02 vol.% O₂ per 10 °C

– On sensitivity: ≤ 0.1 % of measured value per 10 °C

Thermostat temperature = 64 °C

Air pressure effect

– On sensitivity without pressure correction:

≤ 1 % of measured value per 1 % air pressure change

– On sensitivity with pressure correction using integrated pressure sensor (optional):

≤ 0.1 % of measured value per 1 % air pressure change;

for highly suppressed measurement ranges

≤ 0.01 % of measured value per 1 % air pressure change or

≤ 0.002 vol.% O₂ per 1 % air pressure change, whichever is greater.

Pressure sensor working range: p_{abs} = 600 to 1250 hPa

Power supply effect

24 VDC ± 5 %: ≤ 0.4 % of span

Position effect

Zero-point shift ≤ 0.05 vol.% O₂ per 1° deviation from

horizontal location. Position has no effect on the hard-mounted unit.

Dynamic response

Warm-up time

< 1 hour

90% response time

T₉₀ ≤ 3.5 to 10 sec at a sample gas flow of 90 l/h and elec-

tronic T90 time (static/dynamic) = 3/0 sec, gas change from

nitrogen to air (applies to an analyzer unit with 1 analyzer

module)

Calibration

Zero-point calibration

With oxygen-free process gas or substitute gas

End-point calibration

With process gas with a known oxygen concentration or a

substitute gas such as dried air

Single-point calibration

For measurement ranges from 0–5 to 0–25 vol.% O₂:

Zero-point calibration with any oxygen concentration, e.g.

with nitrogen or ambient air, processed through a cooler or

H₂O absorber.

Pressure correction by means of pressure sensor is recom-

mended for single-point calibration with air.

Depending on the measurement task involved, the zero- and

end-points should be verified periodically (recommendation:

once a year).

Calibration of measurement ranges with suppressed zero-point

Highly suppressed measurement ranges (≥95 to 100 vol.% O₂)

should only be calibrated with test gases with concentrations

in the selected measurement range.

Single-point calibration can also be done within a suppressed

measurement range. The O₂ concentration of the test gas must

lie within the measurement range.

Oxygen analyzer module Magnos206

Materials in contact with the sample medium

Analyzer

Rust- and acid-resistant steel 1.4305 (SAE 303), glass, platinum, rhodium, epoxy resin; FPM seals, optional: FFKM75

Pressure sensor

Silicone gel, plastics, FPM

Sample gas inlet conditions

Temperature

+5 to +50 °C

The sample gas dew point should be at least 5 °C below the ambient temperature throughout the sample gas path. Otherwise a sample gas cooler or condensate trap is required. Water vapor content variations cause volume errors.

Pressure

Operation under atmospheric pressure: The sample gas outlet is open to atmosphere. Internal pressure drop < 5 hPa with standard flow rate 60 l/h. Permissible absolute pressure range: 800 to 1250 hPa. Operation under lower absolute pressure (e.g. at altitudes above 2000 m) on request.

Operation under elevated pressure: A pressure sensor is required for pressure influence compensation. Absolute pressure ≤ 1250 hPa: An optional internal pressure sensor can be connected to the sample gas path. Absolute pressure ≥ 1250 hPa: An internal pressure sensor must be connected to the sample gas path.

The analyzer module is type-tested for 5000 hPa internal pressure without damage.

Flow rate

30 to 90 l/h

Changes in gas flow rates should be avoided when using highly suppressed measurement ranges.

Corrosive gases

Consultation with ABB Analytical is required if the sample gas contains Cl_2 , HCl, HF or other corrosive components. FFKM75 seals must be used if the sample gas contains NH_3 . In this case the pneumatics module cannot be connected to the analyzer module. The pressure sensor must not be connected to the sample gas path.

Flammable gases

The analyzer module is suitable for measuring flammable gases and vapors under atmospheric conditions ($p_{\text{abs}} \leq 1.1$ bar, oxygen content ≤ 21 vol.%). Temperature class: T4. The sample gas must not be explosive under normal conditions. If the sample gas is explosive in the event of a sample gas supply failure, then only seldom and briefly (in accordance with zone 2). Pressure in the sample gas path in normal operation $p_e \leq 100$ hPa; in case of a sample gas supply failure the pressure must not exceed the maximum value $p_e = 500$ hPa. Before using the analyzer module the corrosion resistance against the specific sample gas must be checked.

Housing purge with nitrogen should be provided when measuring flammable gases and vapors. Flame barriers can be used as an option (except for the "safety concept" version, see page 34). Pressure drop at the flame barriers approx. 40 hPa for a sample gas flow rate of 50 l/h. Material of the flame barriers: Stainless steel 1.4571 (SAE 316Ti). The pressure sensor must not be connected to the sample gas path.

Version in category 3G see page 34

Gas connections

The sample cell is connected directly to the gas ports.

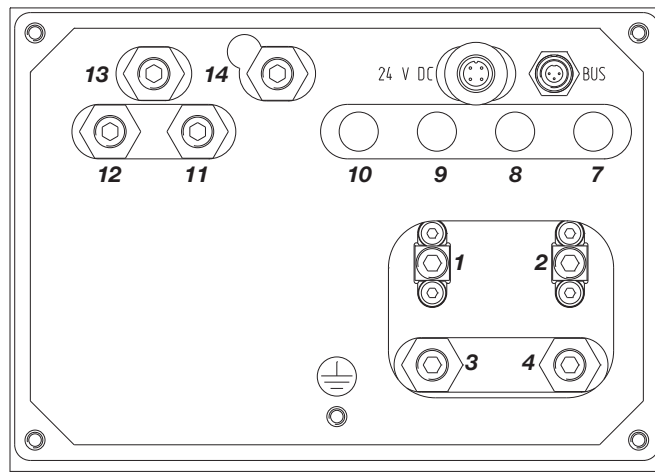

- 1** Sample gas inlet
 - 2** Sample gas outlet
 - 3** Purge gas inlet analyzer²⁾
 - 4** Purge gas outlet analyzer²⁾
 - 7** Purge gas inlet housing¹⁾
 - 8** Purge gas outlet housing¹⁾ (also with flow sensor)
 - 9** Pressure sensor 1¹⁾
 - 10** Pressure sensor 2¹⁾
- Pneumatics module¹⁾:
- 11** Sample gas inlet
 - 12** End point gas inlet (with 3 solenoids)
 - 13** Test gas/zero-point gas inlet (with 1 or 3 solenoids)
 - 14** Sample gas outlet – connect with inlet **1**
- 1) Option
2) not in version with performance test for emission monitoring

Measurement principle

Paramagnetic behavior of oxygen
Heavy-duty thermomagnetic analyzer

Sample component and measurement ranges

Sample component
Oxygen (O₂) in flue gas or in nitrogen

Smallest measurement range
0 to 3 vol.% O₂

Measurement range quantity
1 to 4 measurement ranges
Ranges are factory-set per customer order.

Largest measurement range
0 to 100 vol.% O₂
Measurement ranges within ignition limits cannot be provided.

Stability

Linearity deviation
≤ 2 % of span

Repeatability
≤ 1 % of span

Zero drift
≤ 1 % of span per week

Sensitivity drift
≤ 2 % of measured value per week

Output fluctuation (2 σ)
≤ 0.5 % of smallest measurement range span at electronic
T₉₀ time = 0 sec

Detection limit (4 σ)
≤ 1 % of smallest measurement range span at electronic
T₉₀ time = 0 sec

Influence effects

Flow effect
≤ 1 % of span at a flow change of ±10 l/h. At an identical flow rate for test and sample gases the flow rate effect is automatically compensated.

Associated gas effect
The calibration applies only to the sample gas (= sample component + associated gas) shown on the identification plate.

Temperature effect
Ambient temperature in permissible range
– At zero-point: ≤ 2 % of span per 10 °C
– On sensitivity: ≤ 0.5 % of measured value per 10 °C relative to temperature at the time of calibration
Thermostat temperature = 63 °C

Air pressure effect
– At zero-point: < 0.05 vol.% O₂ per 1 % air pressure change
– On sensitivity without pressure correction:
≤ 1.5 % of measured value per 1 % air pressure change
– On sensitivity with pressure correction:
≤ 0.25 % of measured value per 1 % air pressure change
Option: Calibration for operating altitude over 2000 m

Power supply effect
24 VDC ± 5 %: ≤ 0.2 % of span

Position effect
Approx. 3 % of smallest measurement range span per 1° deviation from horizontal orientation. Position has no effect on the hard-mounted unit.

Dynamic response

Warm-up time
2 to 4 hours

90% response time
T₉₀ = 10 to 22 sec, depending on sample gas flow and on measurement cell connection (see "Gas connections", applies to an analyzer unit with 1 analyzer module)

Calibration

Zero-point calibration
With oxygen-free process gas or substitute gas

End-point calibration
With process gas having a known oxygen concentration or with substitute gas

Oxygen analyzer module Magnos27

Materials in contact with the sample medium

Analyzer

Rust- and acid-resistant steel 1.4580 (SAE 316Cb) and 1.4305 (SAE 303), glass

Gas lines and connectors

Rust- and acid-resistant steel 1.4571 (SAE 316Ti) and 1.4305 (SAE 303), PVC-C, FPM

Sample gas inlet conditions

Temperature

+5 to +50 °C

The sample gas dew point should be at least 5 °C below the ambient temperature throughout the sample gas path. Otherwise a sample gas cooler or condensate trap is required.

Water vapor content variations cause volume errors.

Pressure

The analyzer module is operated under atmospheric pressure; the sample gas outlet is open to atmosphere. Internal pressure drop < 5 hPa with standard flow rate 60 l/h. Permissible absolute pressure range: 800 to 1250 hPa. Operation under lower absolute pressure (e.g. at altitudes above 2000 m) on request. Overpressure in the sample cell max. 500 hPa.

Flow rate

20 to 90 l/h

Flammable gases

Measurement of flammable gases is not possible.

Gas connections

Sample cell connection by means of FPM hoses

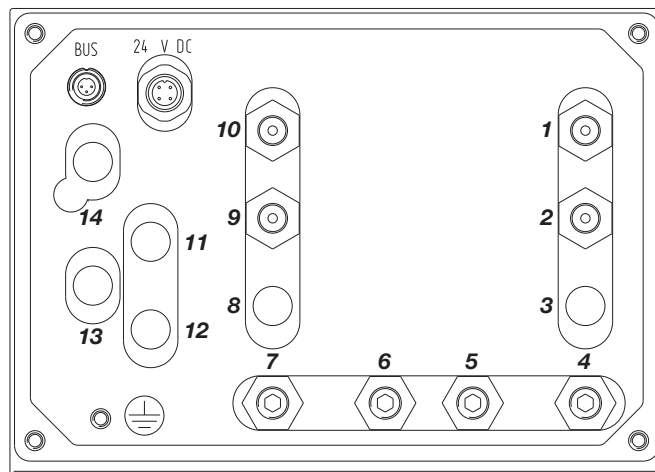

Sample cell direct connection

The sample cell is connected directly to the gas ports (for wall-mount housing only). Application e.g. when external gas supply is connected and for short T_{90} times.

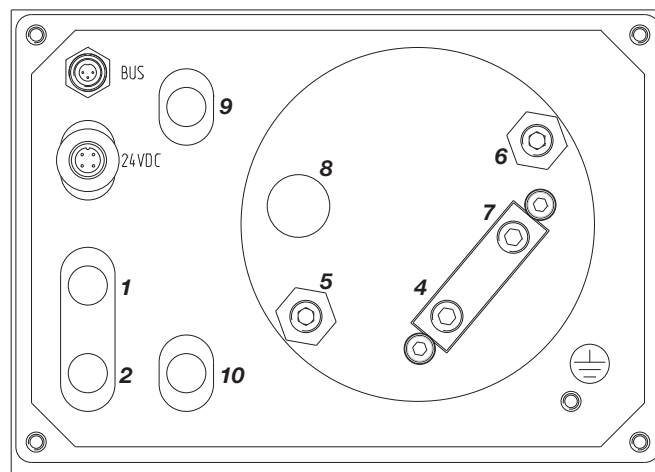

- 1 Purge gas inlet housing ¹⁾
 - 2 Purge gas outlet housing ¹⁾ (also with flow sensor)
 - 3 –
 - 4 Sample gas inlet
 - 5 Purge gas inlet analyzer
 - 6 Purge gas outlet analyzer
 - 7 Sample gas outlet
 - 8 –
 - 9 Pressure sensor 1 ¹⁾
 - 10 Pressure sensor 2 ¹⁾
- Pneumatics module ²⁾:
- 11 Sample gas inlet
 - 12 End point gas inlet (with 3 solenoids)
 - 13 Test gas/zero-point gas inlet (with 1 or 3 solenoids)
 - 14 Sample gas outlet – connect with sample gas inlet 4
- 1) Option
2) Option – not in version with sample cell direct connection

Measurement principle

Potentiometric measurement; zirconium dioxide cell for determination of the oxygen concentration in accordance with Nernst's equation; reference gas: ambient air.

The analyzer module is used for the continuous measurement of oxygen in pure gases (N₂, CO₂, Ar). The measuring cell is catalytically inactivated to the extent that flammable carrier components in stoichiometric concentrations only negligibly reduce the oxygen value.

Sample component and measurement ranges

Sample component
Oxygen (O₂)

Measurement range quantity and limits
4 measurement ranges

Measurement ranges are freely adjustable within the 0 to 1 ppm to 0 to 250,000 ppm O₂ range; they are factory-set to 0 to 1/10/100/1000 ppm O₂

The following measurement data refer to a measurement span of 100 ppm O₂ with a regulated flow rate of 8 ± 0.2 l/h.

Stability

Linearity

Owing to the measurement principle, zirconium dioxide cells are base linear.

Repeatability

< 1 % of the measurement range or 100 ppb O₂ (whichever is greater)

Zero drift

The zero point (reference point) is displayed if ambient air is present on the sample gas side. The value for air of 20.6 vol.% O₂ (for 25 °C and 50 % relative humidity) may deviate through aging of the cell.

< 1 % of the measurement range per week or 250 ppb O₂ (whichever is greater)

Sensitivity drift

Depends on possible interfering components (catalyst poisons) in the sample gas and the aging of the cell. For pure gas measurements in N₂, CO₂ and Ar: < 1 % of the measurement range per week or 250 ppb O₂ (whichever is greater)

Output fluctuation (2 σ)

< ± 0.5 % of the measured value or 50 ppb O₂ (whichever is greater)

Detection limit (4 σ)

< ± 1 % of the measured value or 100 ppb O₂ (whichever is greater)

Influence effects

Flow effect

≤ 300 ppbv O₂ in the permissible range

Associated gas effect

Inert gases (Ar, CO₂, N₂) have no effect. Flammable gases (CO, H₂, CH₄) in stoichiometric concentrations to the oxygen content: Conversion of O₂ < 20 % of the stoichiometric conversion. If higher concentrations of flammable gases are present, higher O₂ conversions must be expected. The concentration of flammable gases in the sample gas must not exceed 100 ppm.

Temperature effect

The effect of the ambient temperature in the permissible range of +5 to +45 °C is < 2 % of the measured value or 50 ppb O₂ per 10 °C change in the ambient temperature (whichever is greater).

Air pressure effect

No effect through a change in air pressure; sample gas must flow out of the outlet without back pressure.

Power supply effect

24 VDC ± 5 %: no effect

Position effect

No position effect for permanently installed instruments

Dynamic response

Warm-up time

The operating temperature of the cell is reached after approx. 15 min. Offset calibration with reference gas (ambient air) after 2 h flow. The measurement is ready-to-run after valves and lines have been purged with sample gas. Typical purging time for valves and lines: approx. 2 to 5 h.

90% response time

T₉₀ < 60 s for the alternation of 2 test gases in the measurement range 10 ppm with a sample gas flow rate = 8 l/h and electronic T90 time = 3 s

Calibration

Offset calibration

The reference value for ambient air is calibrated at 20.6 vol.% O₂ by means of ambient air on the sample gas side.

End-point calibration

By means of test gas O₂ in N₂ (or in CO₂ or Ar); O₂ concentration in the measurement range, e.g. 10 ppm O₂

Function test

Extended response time or reduced sensitivity are dimensions for the correct functioning of the measuring cell. The function test can be carried out without any additional test gases by feeding the sample gas with constant concentration. On the basis of the progression of the test, it can be assessed whether the reaction time of the sensor lies within a specified tolerance. The function test is started manually and lasts approx. 15 min. An additional function block configuration is required for a cyclic scan.

Trace oxygen analyzer module Z023

Materials in contact with the sample medium

Analyzer

Zirconium dioxide cell: ZrO_2 , electrodes containing platinum;
Dust filter (option): Flow sensor (option): on semiconductor basis, nickel-plated brass

Gas lines and connectors

Stainless steel 1.4571 (SAE 316Ti), FPM and silicon hoses in the gas outlet; Gas connections: stainless steel 1.4401/1.4305 (SAE 316/SAE 303)

Sample gas inlet conditions

The analyzer module must not be used for measurement of ignitable gas/air or gas/oxygen mixtures.

Temperature

+5 to +50 °C

Inlet pressure

$p_e \leq 70$ hPa

Outlet pressure

Atmospheric pressure

Flow rate

4 to 20 l/h. Use a metering valve to set the flow rate.

Corrosive gases

The presence of corrosive gases and catalyst poisons, e.g. halogens, gases containing sulfur and heavy-metal dust, leads to faster aging and/or destruction of the ZrO_2 cell.

Flammable gases

The analyzer is suitable for measuring flammable gases in general purpose environment. The concentration of flammable gases in the sample gas must not exceed 100 ppm.

Purge gas

If case purging is selected, purging may only be carried out with air (not with nitrogen), since the ambient air is used as a reference gas.

Note

The trace oxygen analyzer module cannot be connected to the pneumatics module.

Gas connections

The measuring chamber is connected to the sample gas inlet connection via a stainless steel tube (inlet side) and to the sample gas outlet connection via a FPM hose (outlet side).

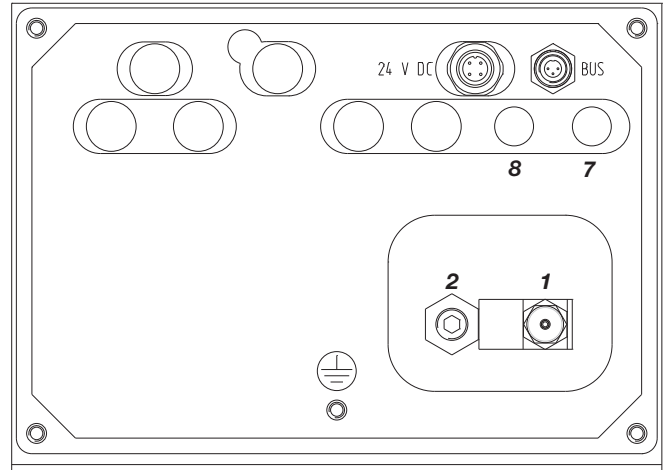

- 1 Sample gas inlet 3 mm Swagelok®
- 2 Sample gas outlet 1/8 NPT internal thread
- 7 Purge gas inlet housing (only for IP54 version)
- 8 Purge gas outlet housing (only for IP54 version)

Thermal conductivity analyzer module Caldos25

Measurement principle

Difference in thermal conductivity of various gases

Highly corrosion-resistant thermal conductivity analyzer, sample cells embedded in glass

Sample components and measurement ranges

The Caldos25 is specifically designed for measurements of corrosive gas components.

Sample components and smallest measurement ranges (examples)

Component and associated gas	Smallest measurement range	Reference gas
H ₂ in N ₂ or air	0–0.5 vol. %	Air (sealed)
SO ₂ in N ₂ or air	0–1.5 vol. %	Air (sealed)
H ₂ in Cl ₂	0–0.5 vol. %	Flowing

Measurement range quantity and limits

1 to 4 measurement ranges per sample component
Ranges are factory-set per customer order.

Largest measurement range

0 to 100 vol. % or 0 vol. % to saturation
Measurement ranges within ignition limits cannot be provided.

Measurement range switching ratio

≤ 1:20

Measurement ranges with suppressed zero-point

Span at least 2 vol. %, depending on application

Stability

Linearity deviation

≤ 2 % of span

Repeatability

≤ 1 % of span

Zero drift

≤ 1 % of span per week

Sensitivity drift

≤ 1 % of measured value per week

Output fluctuation (2 σ)

≤ 0.5 % of smallest measurement range span at electronic
T₉₀ time = 0 sec

Detection limit (4 σ)

≤ 1 % of smallest measurement range span at electronic
T₉₀ time = 0 sec

Influence effects

Flow effect

≤ 1 to 5 % of span at a flow change of ±10 l/h. At an identical flow rate for test and sample gases the flow rate effect is automatically compensated.

Associated gas effect

Analyzer calibration should be based on an analysis of the sample gas. Measurement results can be greatly distorted by interfering components in complex (non-binary) gas mixtures.

Temperature effect

Ambient temperature in permissible range
at each point in the measurement range: ≤ 1 % of span per 10 °C, based on temperature at the time of calibration
Thermostat temperature = 60 °C

Air pressure effect

No effect in permissible operating condition range

Power supply effect

24 VDC ± 5 %: ≤ 0.2 % of span

Position effect

< 1 % of span up to 10° deviation from horizontal orientation

Dynamic response

Warm-up time

1.5 hours

90% response time

Typical T₉₀ = 10 to 20 sec; optional: T₉₀ < 6 sec
(applies to an analyzer unit with 1 analyzer module)

Calibration

Zero-point calibration

With sample component-free process gas or substitute gas

End-point calibration

With process gas having a known sample gas concentration or with substitute gas

Thermal conductivity analyzer module Caldos25

Materials in contact with the sample medium

Analyzer

Rust- and acid-resistant steel 1.4305 (SAE 303), glass

Gas lines and connectors

For sealed reference gas: Rust- and acid-resistant steel 1.4305 (SAE 303);

For flowing reference gas: PVC-C, FPM seals;

For corrosive sample gas: PVC-C, FPM seals; if the sample gas contains NH_3 , FFKM seals are used.

Sample gas inlet conditions

Temperature

+5 to +50 °C

The sample gas dew point should be at least 5 °C below the ambient temperature throughout the sample gas path. Otherwise a sample gas cooler or condensate trap is required.

Water vapor content variations cause volume errors.

Pressure

The analyzer module is operated under atmospheric pressure; the sample gas outlet is open to atmosphere. Internal pressure drop < 5 hPa with standard flow rate 60 l/h. Permissible absolute pressure range: 800 to 1250 hPa. Operation under lower absolute pressure (e.g. at altitudes above 2000 m) on request. Overpressure in the sample cell max. 500 hPa.

Flow rate

10 to 90 l/h, max. 90 to 200 l/h for option $T_{90} < 6$ sec

Flowing reference gas

Gas inlet conditions same as sample gas

Flammable gases

The analyzer module is suitable for measuring flammable gases and vapors under atmospheric conditions ($p_{\text{abs}} \leq 1.1$ bar, oxygen content ≤ 21 vol.%). Temperature class: T4. The sample gas must not be explosive under normal conditions. If the sample gas is explosive in the event of a sample gas supply failure, then only seldom and briefly (in accordance with zone 2). Pressure in the sample gas path in normal operation $p_e \leq 100$ hPa; in case of a sample gas supply failure the pressure must not exceed the maximum value $p_e = 500$ hPa. Before using the analyzer module the corrosion resistance against the specific sample gas must be checked.

Housing purge with nitrogen should be provided when measuring flammable gases and vapors. Flame barriers can be used as an option (except for the "safety concept" version, see page 34). Pressure drop at the flame barriers approx. 40 hPa for a sample gas flow rate of 50 l/h. Material of the flame barriers: Stainless steel 1.4571 (SAE 316Ti).

Version in category 3G see page 34

Gas connections

Standard version

The sample cell is connected directly to the gas ports.

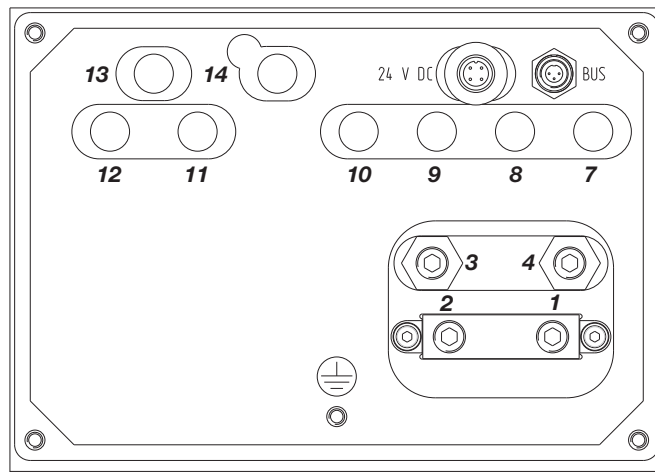

Versions for corrosive sample gas or flowing reference gas

The sample cell is connected directly to the gas ports.

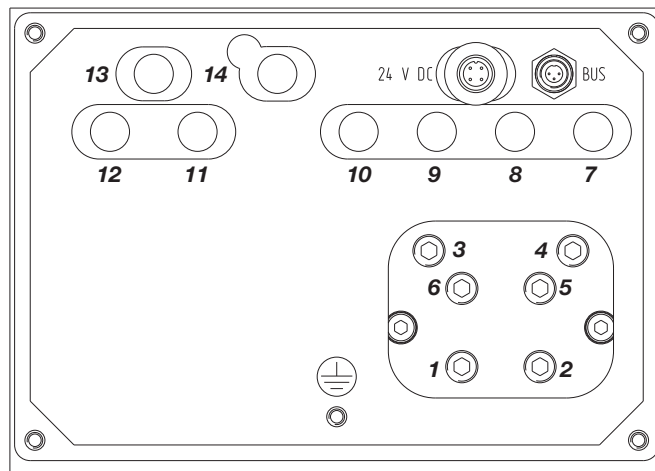

- | | |
|--|---|
| <ul style="list-style-type: none"> 1 Sample gas inlet 2 Sample gas outlet 3 Purge gas inlet analyzer 4 Purge gas outlet analyzer 5 Reference gas inlet ²⁾ 6 Reference gas outlet ²⁾ 7 Purge gas inlet housing ¹⁾ 8 Purge gas outlet housing ¹⁾ (also with flow sensor) 9 Pressure sensor 1 ¹⁾ 10 Pressure sensor 2 ¹⁾ Pneumatics module ^{1) 2)}: 11 Sample gas inlet 12 End point gas inlet (with 3 solenoids) 13 Test gas/zero-point gas inlet (with 1 or 3 solenoids) 14 Sample gas outlet – connect with sample gas inlet 1 | <p>Caution!</p> <p>In versions for corrosive sample gas or flowing reference gas, gas ports 1 to 6 are made of PVC-C. Do not use metal adapters or hose nozzles!</p> |
|--|---|
- 1) Option
2) Not in version for corrosive sample gas

Thermal conductivity analyzer module Caldos27

Measurement principle

Difference in thermal conductivity of various gases

Micromechanical silicon sensor with especially short T_{90} time

Sample components and measurement ranges

Sample components and smallest possible measurement ranges (examples)

Component and associated gas	Measurement ranges		Standard gas ¹⁾ for calibration
	class 1	class 2	
Ar in O ₂	0–20	0–2	vol.% Air, N ₂ , O ₂
H ₂ in Ar	0–2.5	0–0.25	vol.% Air, N ₂ , Ar
H ₂ in N ₂ /air	0–3	0–0.3	vol.% Air, N ₂
H ₂ in stack gas	0–5	0–0.5	vol.% Air, N ₂
CH ₄ in N ₂	0–20	0–2	vol.% Air, N ₂
CH ₄ in air	0–4	0–2	vol.% Air, N ₂
CO ₂ in N ₂ /air	0–30	0–3	vol.% Air, N ₂
Ar in N ₂	75–100	97.5–100	vol.% Air, N ₂ , Ar
H ₂ in N ₂	90–100	97–100	vol.% N ₂ , H ₂
		99–100 ²⁾	vol.% N ₂ , H ₂
CH ₄ in N ₂	90–100	99–100	vol.% N ₂ , CH ₄
He in N ₂	90–100	97–100	vol.% He

1) Only for measurement ranges \geq class 1

2) Daily zero-point check required

Sample components and measurement ranges for monitoring hydrogen-cooled turbo generators

Component and associated gas	Measurement range
CO ₂ in air	0–100 vol.%
H ₂ in CO ₂	100–0 vol.%
H ₂ in air	100–80/90 vol.%

Other sample components on request.

Measurement range quantity and limits

1 to 4 measurement ranges per sample component. Range limits are freely adjustable. They are factory-calibrated for the largest possible measurement range.

Largest measurement range

0 to 100 vol.% or 0 vol.% to saturation, depending on measurement task. Measurement ranges within ignition limits cannot be provided.

Measurement range switching ratio

$\leq 1:20$

Measurement ranges with suppressed zero-point

See the table above for spans

Stability

These data apply only to measurement ranges \geq class 2.

Linearity deviation

$\leq 2\%$ of span

Repeatability

$\leq 1\%$ of span

Zero drift

$\leq 2\%$ of smallest possible measurement range per week

Sensitivity drift

$\leq 0.5\%$ of smallest possible measurement range per week

Output fluctuation (2σ)

$\leq 0.5\%$ of smallest measurement range span at electronic T_{90} time = 0 sec

Detection limit (4σ)

$\leq 1\%$ of smallest measurement range span at electronic T_{90} time = 0 sec

Influence effects

Flow effect

$\leq 0.5\%$ of span at a flow change of ± 10 l/h. At an identical flow rate for test and sample gases the flow rate effect is automatically compensated.

Associated gas effect

The knowledge of the sample gas composition is necessary for the analyzer configuration.

Temperature effect

Ambient temperature in permissible range
at each point in the measurement range: $\leq 0.5\%$ of span per 10°C , based on temperature at the time of calibration
Thermostat temperature = 60°C

Air pressure effect

$\leq 0.25\%$ of span per 10 hPa for the smallest possible ranges given; for larger spans the effect is correspondingly lower.
Pressure sensor working range: $p_{\text{abs}} = 600$ to 1250 hPa
Option: Calibration for operating altitude over 2000 m

Power supply effect

24 VDC $\pm 5\%$: $\leq 0.2\%$ of span

Position effect

$< 1\%$ of span up to 30° deviation from horizontal orientation

Dynamic response

Warm-up time

Approx. 30/60minutes for class 1/2 measurement ranges

90% response time

$T_{90} \leq 2$ sec for direct sample cell connection and sample gas flow of 60 l/h
(applies to an analyzer unit with 1 analyzer module)

Calibration

Zero-point calibration

With test gas, measurement component-free process gas or substitute gas

End-point calibration

With test gas, process gas having a known sample gas concentration or substitute gas

Simplified calibration with standard gas

For measurement ranges \geq class 1, a single-point calibration can be performed with standard gas, since the zero- and end-points will not drift independently due to the sensor principle employed.

This technique leaves out safety-related measurements.

Depending on the measurement task involved, the zero- and end-points should be verified periodically (recommendation: once a year).

Thermal conductivity analyzer module Caldos27

Materials in contact with the sample medium

Analyzer

Sample cell: Stainless steel 1.4305 (SAE 303); sensor: Gold, silicon oxo-nitride; seal: FFKM75

Sample gas inlet conditions

Temperature

+5 to +50 °C

The sample gas dew point should be at least 5 °C below the ambient temperature throughout the sample gas path. Otherwise a sample gas cooler or condensate trap is required.

Water vapor content variations cause volume errors.

Pressure

The analyzer module is operated under atmospheric pressure; the sample gas outlet is open to atmosphere. Internal pressure drop < 5 hPa with standard flow rate 60 l/h. Permissible absolute pressure range: 800 to 1250 hPa. Operation under lower absolute pressure (e.g. at altitudes above 2000 m) on request. Overpressure in the sample cell max. 500 hPa.

Flow rate

Normally 10 to 90 l/h, minimum 1 l/h

Corrosive gases

Consultation with ABB Analytical is required if the sample gas contains Cl₂, HCl, HF, SO₂, NH₃, H₂S or other corrosive components.

FPM hoses should not be used if the sample gas contains NH₃. Instead, FFKM hoses should be used. In this case the pneumatics module cannot be connected to the analyzer module.

Flammable gases

The analyzer module is suitable for measuring flammable gases and vapors under atmospheric conditions ($p_{abs} \leq 1.1$ bar, oxygen content ≤ 21 vol.%). Temperature class: T4. The sample gas must not be explosive under normal conditions. If the sample gas is explosive in the event of a sample gas supply failure, then only seldom and briefly (in accordance with zone 2). Pressure in the sample gas path in normal operation $p_e \leq 100$ hPa; in case of a sample gas supply failure the pressure must not exceed the maximum value $p_e = 500$ hPa.

Before using the analyzer module the corrosion resistance against the specific sample gas must be checked.

Housing purge with nitrogen should be provided when measuring flammable gases and vapors. Flame barriers can be used as an option (except for the "safety concept" version, see page 34). Pressure drop at the flame barriers approx.

40 hPa for a sample gas flow rate of 50 l/h. Material of the flame barriers: Stainless steel 1.4571 (SAE 316Ti).

Version in category 3G see page 34

Gas connections

The sample cell is connected directly to the gas ports.

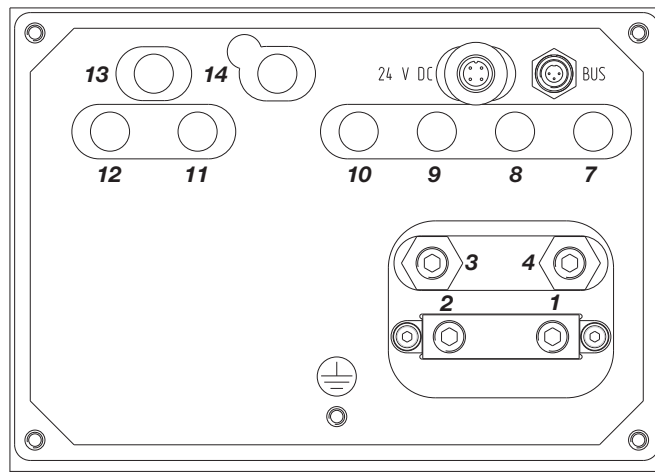

- 1** Sample gas inlet
 - 2** Sample gas outlet
 - 3** Purge gas inlet analyzer
 - 4** Purge gas outlet analyzer
 - 7** Purge gas inlet housing ¹⁾
 - 8** Purge gas outlet housing ¹⁾ (also with flow sensor)
 - 9** Pressure sensor 1
 - 10** Pressure sensor 2
 - Pneumatics module ¹⁾:
 - 11** Sample gas inlet
 - 12** End point gas inlet (with 3 solenoids)
 - 13** Test gas/zero-point gas inlet (with 1 or 3 solenoids)
 - 14** Sample gas outlet – connect with sample gas inlet **1**
- 1) Option

FID analyzer module Fidas24

Measurement principle

Flame-ionization detector

The analyzer module complies with the requirements for measuring instruments with flame ionization detection according to EN 12619.

Sample components and measurement ranges

Sample components

Hydrocarbons. The concentration of the gas components in the sample gas path must not exceed the temperature-dependent LEL. The analyzer temperature is 180 °C.

Number of sample components

4 sample components

Smallest measurement range

0–5 to 0–1500 mg org. C/m³ or 0–10 to 0–3000 ppm C1

Largest measurement range

0 to 80 g org. C/m³ or 0 to 15 vol.% C1

Larger measurement ranges on request.

Measurement range quantity and limits

1 to 4 measurement ranges

Measurement ranges are factory-set per customer order.

Smallest to largest measurement range ratio 1:300 to 1:1500, depending on the configuration.

Stability

The following data apply only if all influence factors (e.g. flow rate, temperature, atmospheric pressure) are constant. They apply to measurement ranges ≥ 50 mg org. C/m³, for smaller ranges these only apply if they are factory-set per customer order.

Linearity deviation

$\leq 2\%$ of the span to 5000 mg org. C/m³

this value applies in one (calibrated) measurement range

Repeatability

$\leq 0.5\%$ of measurement range

Zero-point and sensitivity drift

≤ 0.5 mg org. C/m³ per week

Output fluctuation at zero-point (2 σ)

$\leq 0.5\%$ of span at electronic T90 time = 20 sec

Detection limit (4 σ)

$\leq 1\%$ of span at electronic T90 time = 20 sec

Influence effects

Oxygen dependence

$\leq 2\%$ of measured value for 0–21 vol.% O₂ or

≤ 0.3 mg org. C/m³, the larger value applies

Temperature effect

Ambient temperature in permissible range

at zero-point and on sensitivity: $\leq 2\%$ of measured value per

10 °C or ≤ 300 ppb C1 per 10 °C

Power supply effect

24 VDC $\pm 5\%$: $\leq 0.2\%$ of span or

230 VAC $\pm 10\%$: $\leq 0.2\%$ of span

Dynamic response

Warm-up time

≤ 2 hours

90% response time

T₉₀ < 1.5 s at sample gas flow = 80 l/h and electronic T90 time = 1 sec

Calibration

Zero-point calibration

With synthetic air or catalytically purified air or nitrogen, depending on application

Sensitivity calibration

With propane or another hydrocarbon (substitute gas) in air or nitrogen, depending on application

Materials in contact with the sample medium

Analyzer, gas lines and connectors

Stainless steel 1.4305 (SAE 303) and 1.4571 (SAE 316Ti), FPM, PTFE, FFKM

Operating gases and test gases

Instrument air

Quality per ISO 8573-1 class 2 (max. particle size 1 μ m, max. particle concentration 1 mg/m³, max. oil content 0.1 mg/m³, pressure dew point at least 10 °C below the lowest foreseeable ambient temperature)

Inlet pressure p_e = 4000 \pm 500 hPa

Flow rate typically approx. 1800 l/h (1200 l/h for air injector and approx. 600 l/h for housing purge), maximum approx. 2200 l/h (1500 l/h + 700 l/h)

Combustion air

Synthetic air or catalytically purified air with an organic C content < 1% span

Inlet pressure p_e = 1200 \pm 100 hPa

Flow rate < 20 l/h

Combustion gas

Hydrogen, grade 5.0, or H₂/He mixture (40/60%)

Inlet pressure p_e = 1200 \pm 100 hPa

Flow rate ≤ 3 l/h (H₂) or approx. 10 l/h (H₂/He)

A flow limiting device must be provided on the hydrogen supply (see section "Safe operation of the gas analyzer").

Test gases

Zero-point calibration: Nitrogen, grade 5.0, or synthetic air or catalytically purified air

Sensitivity calibration: Sample component or substitute gas component in nitrogen or air

Inlet pressure p_e = 1000 \pm 100 hPa

Flow rate 130 to 250 l/h

FID analyzer module Fidas24

Sample gas inlet conditions

The sample gas may not be explosive at any time.

The analyzer module must not be used for measurement of gases containing organometallic compounds, e.g. leaded gasoline additives or silicone oils.

Temperature

≤ thermostat temperature

(Thermostat temperature for sample gas path, detector and air injector ≤ 200 °C, factory-set to 180 °C)

Inlet pressure

$p_{\text{abs}} = 800$ to 1100 hPa

Outlet pressure

Atmospheric pressure

Flow rate

Approx. 80 to 100 l/h at atmospheric pressure (1000 hPa)

Humidity

≤ 40 % H₂O

Flammable gases

The analyzer module can be used for measurement of flammable gases as long as the total flammable portion does not exceed 15 vol.% CH₄ or C1 equivalents.

Safe operation of the gas analyzer

The device concept ensures that a concentration of combustible gas or an explosive mixture of combustible gas and ambient air cannot occur in the interior of the gas analyzer during normal operation. The interior of the gas analyzer cannot be allocated to an (explosion protection) zone; an explosive gas mixture cannot escape to the outside.

The end user must make the following provisions to ensure safe operation of the gas analyzer:

- The combustion gas flow rate must be limited to a maximum of 10 l/h of H₂ or 25 l/h of H₂/He mixture. For this purpose, the end user has to provide suitable measures outside the gas analyzer.
- A shut-off valve must be installed in the combustion gas supply line to increase the safety in the following operating states: Shutting down the gas analyzer, failure of the instrument air supply, leakage in the combustion gas feed path inside the gas analyzer. This shut-off valve should be installed outside the analyzer house in the vicinity of the combustion gas supply.

Gas and electrical connections

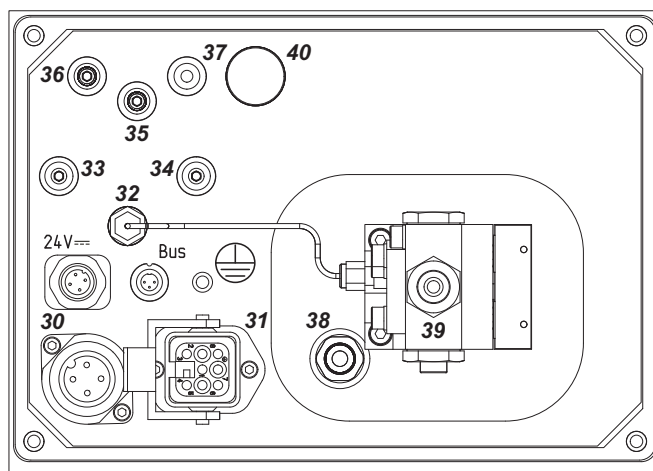

30 Power supply 115 or 230 VAC for heating of detector and sample gas inlet (4-pin male plug, connecting cable supplied)

31 Electrical connection to heated sample gas inlet (fixed)

32 Test gas outlet

33 Zero-point gas inlet

34 End-point gas inlet

35 Combustion air inlet

36 Combustion gas inlet

37 Instrument air inlet

38 Exhaust outlet (Male fitting for connecting the exhaust air outlet tube: Stainless steel tube with terminal nut and clamping ring, outside diameter = 6 mm, included in the scope of supply and delivery of the gas analyzer. Permissible maximum length of 30 cm; after that point the inner diameter of the exhaust line should be increased to ≥ 10 mm.)

39 Sample gas inlet, heated or unheated (Threaded connection for PTFE or stainless steel tubing with a 6-mm outer diameter)

40 Pressure compensation opening with protection filter

24 V External power supply 24 VDC (4-pin male plug)

Bus System bus (3-pin female plug)

Sample gas line connection

To heated sample gas inlet:

- In wall-mount housing: bottom and right
- In 19-inch housing: back, top and bottom

To unheated sample gas inlet:

- In wall-mount and 19-inch housing: back

Measurement principle

Non-methane flame-ionization detector (NMHC = non-methane hydrocarbons)

The analyzer module complies with the requirements for measuring instruments with flame ionization detection according to EN 12619.

A non-methane converter is used in the analyzer module for the measurement of CH₄.

Sample components and measurement ranges

Sample components

Hydrocarbons. The CH₄:NMHC ratio must be in the 1:9 to 9:1 range. Maximum concentration CH₄: 26500 mg org. C/m³ or 50000 ppm C1. Maximum concentration NMHC: 5000 mg org. C/m³ or 9330 ppm C1. The concentration of the gas components in the sample gas path must not exceed the temperature-dependent LEL. The analyzer temperature is 180 °C.

Number of sample components

2 sample components: CH₄ and THC. The calculated non-methane portion of the hydrocarbons is output as 3rd component NMHC.

Smallest measurement range

0–5 to 0–1500 mg org. C/m³ or 0–10 to 0–3000 ppm C1

Largest measurement range CH₄ and THC

0–50 to 0–25000 mg org. C/m³ or
0–100 to 0–50000 ppm C1

Largest measurement range NMHC

0–5000 mg org. C/m³ or 0–10000 ppm C1

Measurement range quantity and limits

1 to 4 measurement ranges
Measurement ranges are factory-set per customer order.

Stability

The following data apply only if all influence factors (e.g. flow rate, temperature, atmospheric pressure) are constant. They apply to measurement ranges ≥ 50 mg org. C/m³, for smaller ranges these only apply if they are factory-set per customer order.

Linearity deviation

$\leq 2\%$ of the span to 5000 mg org. C/m³
this value applies in one (calibrated) measurement range

Repeatability

$\leq 0.5\%$ of measurement range

Zero-point and sensitivity drift

≤ 0.5 mg org. C/m³ per week

Output fluctuation at zero-point (2σ)

$\leq 0.5\%$ of span at electronic T90 time = 20 sec

Detection limit (4σ)

$\leq 1\%$ of span at electronic T90 time = 20 sec

Influence effects

Oxygen dependence

$\leq 2\%$ of measured value for 0–21 vol.% O₂ or
 ≤ 0.3 mg org. C/m³, the larger value applies

Temperature effect

Ambient temperature in permissible range
at zero-point and on sensitivity: $\leq 2\%$ of measured value per
10 °C or ≤ 300 ppb C1 per 10 °C

Power supply effect

24 VDC $\pm 5\%$: $\leq 0.2\%$ of span or
230 VAC $\pm 10\%$: $\leq 0.2\%$ of span

Dynamic response

Warm-up time

≤ 2 hours

90% response time

T₉₀ < 2.5 s via bypass, T₉₀ < 3 s via converter at sample gas
flow = 80 l/h and electronic T90 time = 1 sec

Switchover time

Between bypass and converter typically 20 s, depending on
measurement range

Converter

Converter service life

The catalyst is a consumable material. Its service life depends on the concentration of the converted hydrocarbons. Catalyst poisons (e.g. SO₂, HCl, H₂S, halogenated hydrocarbons, heavy metals) will shorten the converter service life. Their respective concentration should always be < 20 mg/m³. It is recommended to test the converter function once a year.

Calibration

Zero-point calibration

With synthetic air or catalytically purified air, depending on
application

Sensitivity calibration

With methane or propane in air, depending on application

Materials in contact with the sample medium

Analyzer, gas lines and connectors

Stainless steel 1.4305 (SAE 303) and 1.4571 (SAE 316Ti), FPM,
PTFE, FFKM

Operating gases and test gases

Instrument air

Quality per ISO 8573-1 class 2 (max. particle size 1 μ m, max. particle concentration 1 mg/m³, max. oil content 0.1 mg/m³, pressure dew point at least 10 °C below the lowest foreseeable ambient temperature), inlet pressure p_e = 4000 \pm 500 hPa, flow rate typically approx. 1800 l/h (1200 l/h for air injector and approx. 600 l/h for housing purge), maximum approx. 2200 l/h (1500 l/h + 700 l/h)

Combustion air

Synthetic air or catalytically purified air with an organic C content < 1% span, inlet pressure p_e = 1200 \pm 100 hPa, flow rate < 20 l/h

FID analyzer module Fidas24 NMHC

Combustion gas

Hydrogen (H_2), grade 5.0, or H_2/He mixture (40/60 %), inlet pressure $p_e = 1200 \pm 100$ hPa, flow rate ≤ 3 l/h (H_2) or approx. 10 l/h (H_2/He). A flow limiting device must be provided on the hydrogen supply (see section "Safe operation of the gas analyzer").

Test gases

Zero-point calibration: Synthetic air or catalytically purified air.
Sensitivity calibration: Sample component CH_4 : CH_4 in air, sample component THC: C_3H_8 in air or CH_4 in air.
Inlet pressure $p_e = 1000 \pm 100$ hPa, flow rate 130 to 250 l/h

Test gases for converter effectiveness testing

CH_4 or C_2H_6 in air (separate test gas bottles), connection via bypass, inlet pressure $p_e = 1000 \pm 100$ hPa, flow rate 130 to 250 l/h

Sample gas inlet conditions

The sample gas may not be explosive at any time.

The analyzer module must not be used for measurement of gases containing organometallic compounds, e.g. leaded gasoline additives or silicone oils.

Temperature

\leq thermostat temperature
(Thermostat temperature for sample gas path, detector and air injector ≤ 200 °C, factory-set to 180 °C)

Inlet pressure

$p_{abs} = 850$ to 1100 hPa

Outlet pressure

Atmospheric pressure

Flow rate

Approx. 80 to 100 l/h at atmospheric pressure (1000 hPa)

Humidity

≤ 40 % H_2O

Flammable gases

The analyzer module can be used for measurement of flammable gases as long as the total flammable portion does not exceed 5 vol.% CH_4 or C1 equivalents.

Safe operation of the gas analyzer

The device concept ensures that a concentration of combustible gas or an explosive mixture of combustible gas and ambient air cannot occur in the interior of the gas analyzer during normal operation. The interior of the gas analyzer cannot be allocated to an (explosion protection) zone; an explosive gas mixture cannot escape to the outside.

The end user must make the following provisions to ensure safe operation of the gas analyzer:

- The combustion gas flow rate must be limited to a maximum of 10 l/h of H_2 or 25 l/h of H_2/He mixture. For this purpose, the end user has to provide suitable measures outside the gas analyzer.
- A shut-off valve must be installed in the combustion gas supply line to increase the safety in the following operating states: Shutting down the gas analyzer, failure of the instrument air supply, leakage in the combustion gas feed path inside the gas analyzer. This shut-off valve should be installed outside the analyzer house in the vicinity of the combustion gas supply.

Gas and electrical connections

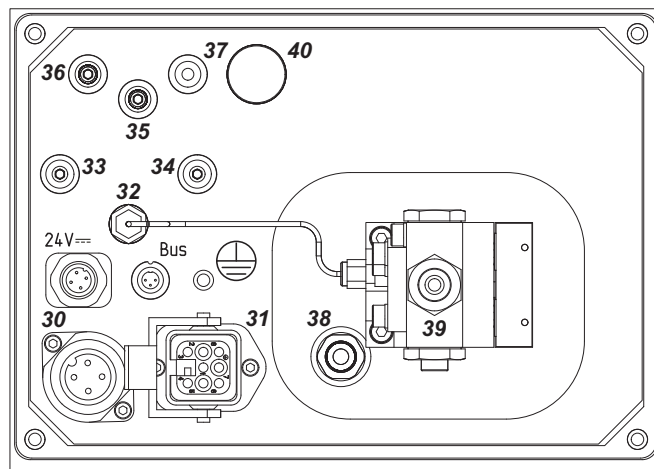

30 Power supply 115 or 230 VAC for heating of detector and sample gas inlet (4-pin male plug, connecting cable supplied)

31 Electrical connection to heated sample gas inlet (fixed)

32 Test gas outlet

33 Zero-point gas inlet

34 End-point gas inlet

35 Combustion air inlet

36 Combustion gas inlet

37 Instrument air inlet

38 Exhaust outlet (Male fitting for connecting the exhaust air outlet tube: Stainless steel tube with terminal nut and clamping ring, outside diameter = 6 mm, included in the scope of supply and delivery of the gas analyzer. Permissible maximum length of 30 cm; after that point the inner diameter of the exhaust line should be increased to ≥ 10 mm.)

39 Sample gas inlet, heated or unheated (Threaded connection for PTFE or stainless steel tubing with a 6-mm outer diameter)

40 Pressure compensation opening with protection filter

24 V External power supply 24 VDC (4-pin male plug)

Bus System bus (3-pin female plug)

Sample gas line connection

To heated sample gas inlet:

- In wall-mount housing: bottom and right
- In 19-inch housing: back, top and bottom

To unheated sample gas inlet:

- In wall-mount and 19-inch housing: back

Laser analyzer module LS25

Measurement principle

The LS25 laser analyzer module is based on a measuring principle called single-line spectroscopy. One single target gas absorption line with no interference is chosen in the near infrared spectral range. A single mode diode laser operating around room temperature scans this single absorption line. A detector diametrically opposite detects the light and the absorption caused only by the target gas molecules. Once the absorption by the target gas molecules is detected, the gas concentration is calculated. Automatic corrections for temperature and pressure variations are included.

Sample components and measurement ranges

The LS25 laser analyzer module has one physical measurement range per sample component. The indicated measurement range can be freely calibrated within the physical measurement range. The smallest detection limits and corresponding measurement ranges are shown in the table below:

Sample component	Min. measurement range	Max. abs. pressure	Max. temperature
O ₂	0– 1 vol. %	10 bar	1500 °C
NH ₃	0– 20 ppm	1.5 bar	500 °C
HCl	0– 5 ppm	1.5 bar	400 °C
HF	0– 3 ppm	1.5 bar	300 °C
H ₂ S	0– 300 ppm	1.5 bar	300 °C
H ₂ O (ppm)	0– 30 ppm	1.5 bar	1300 °C
H ₂ O (vol. %)	0– 1 vol. %	1.5 bar	1500 °C
CO (ppm)	0– 20 ppm	1.5 bar	500 °C
CO (vol. %)	0– 1 vol. %	1.5 bar	600 °C
CO ₂ (ppm)	0– 100 ppm	1.5 bar	300 °C
CO ₂ (vol. %)	0– 1 vol. %	1.5 bar	1500 °C
NO	0– 1500 ppm	1.5 bar	300 °C
N ₂ O	0– 500 ppm	1.5 bar	200 °C
HCN	0– 30 ppm	1.5 bar	300 °C
CH ₄	0– 1 vol. %	1.5 bar	500 °C
NH ₃ + H ₂ O	0– 20 ppm 0– 2 vol. %	1.5 bar	500 °C
HCl + H ₂ O	0– 5 ppm 0– 5 vol. %	1.5 bar	400 °C
HF + H ₂ O	0– 3 ppm 0– 2 vol. %	1.5 bar	300 °C
CO (vol. %) + CO ₂ (vol. %)	0– 1 vol. % 0– 1 vol. %	1.5 bar	600 °C
HCl + CH ₄	0– 300 ppm 0– 1 vol. %	1.5 bar	400 °C
CO (ppm) + CH ₄	0– 20 ppm 0– 100 ppm	1.5 bar	500 °C
CO (ppm) + H ₂ O (vol. %)	0– 100 ppm 0– 5 vol. %	1.5 bar	1500 °C
O ₂ + temp.	0– 1 vol. %	1.5 bar	1500 °C

Other sample components on request.

All specifications refer to an optical path length (OPL) of 1 meter, tested in ABB's test/calibration jig. The standard optical path length ranges from 0.5 to 6 m (larger OPL on request). Application-dependent variations may occur. To obtain minimum measurement ranges in some cases additional measures have to be taken: Low level O₂ and H₂O require instrument and process purging with nitrogen. Actual detection limit for a specific application will depend on the gas conditions (pressure, temperature and gas composition) and optical path length. If more than one

min. measurement range is shown there are different instrument versions available.

Min. measurement range, max. pressure and max. temperature cannot necessarily be realized simultaneously. The maximum pressure and temperature given are physical (spectroscopic) limits. Applications with increased temperature or pressure or with toxic or flammable gas may require additional equipment.

Measurement range quantity

1 range per sample component, 1 x transmission

Largest measurement range

Largest measurement range is generally 100 times the minimum measurement range for the same conditions. Larger measurement ranges are normally possible by adaptation of measuring path and choice of a weaker absorption line.

Stability

Repeatability

± Detection limit or ± 1 % of reading, whichever is greater

Zero drift

< 2 % of smallest possible measurement range per 6 months

Span drift

< 4 % of measurement range per 6 months

Output fluctuation (2 σ)

≤ 0.5 % of smallest measurement range

Detection limit (4 σ)

≤ 1 % of smallest measurement range

Influence effects

Flow effect

No effect on the measurement, but the flow will determine the amount of purge gas needed.

Associated gas effect/cross sensitivity

No cross sensitivity within normal operation conditions.

Temperature effect

- Ambient temperature in permissible range: No significant effect
- Gas temperature effect: Typically ≤ 2 % of measured value per 10 °C (dependent on type of gas and gas conditions). For large variations in gas temperature (> ±20 °C) separate temperature measurement for compensation is recommended.

Pressure effect

- At zero-point: No effect.
- Automatic compensation for large variations in sample gas pressure by measurement of absorption line width, alternatively by input from pressure sensor.

Power supply effect

24 VDC ± 5 %: ≤ 0.2 % of span

Dynamic response

Warm-up time

Approx. 1 hour

Response time

Less than 2 seconds without signal averaging

Laser analyzer module LS25

Calibration

Maintenance interval

Depending on application and dust load. Typically between every 6 months and once a year.

Zero-point check

With inert gas, e.g. nitrogen, or with ambient air free of the sample component. The zero point cannot be calibrated. Due to the measurement principle, there is no zero-point drift.

Calibration

With test gas and a flow-through test cell. Calibration interval typically between every 6 months and once a year. Recommended calibration interval will be stated in calibration certificate which accompanies delivery.

Materials in contact with the process gas

Purge and alignment unit

316 SS

Windows

BK7 glass, optional: fused silica, for HF: sapphire

Mounting

Available flanges

DN50/PN10, DN80/PN10; ANSI 2"/150 lbs, ANSI 2"/300 lbs, ANSI 3"/150 lbs, ANSI 3"/300 lbs

Alignment tolerances

Flanges parallel within 1.5°

Purging of windows

Dry and oil-free pressurized air or gas, or by fan

Gas ports for purging

Standard: 3/8-inch hose nozzle for hoses with 10 mm inner diameter. See page 30 for connection drawing.

Weight

Transmitter unit plus flange with purging unit: 9.5 (6.3 + 3.2) kg
Receiver unit plus flange with purging unit: 7.2 (4.0 + 3.2) kg
Flow-through test cell: 3.8 kg

Electrical connections on transmitter unit

Connection to central unit

Ethernet 10/100BASE-T, RJ45 connector;
Cable length: Standard 15 m, max. 100 m

Connection to receiver unit

15-pin female Sub-D connector;
Cable length: Standard 5 m, max. 150 m

Power supply, external pressure and temperature signals

15-pin male Sub-D connector;
Cable length laser unit–power supply: Standard 3 m, max. 100 m; Cable length power supply–plug: 3 m

Service computer

RS232, 9-pin female Sub-D connector; Ethernet

See page 31 for connection drawing.

Process gas properties

Maximum process gas temperature and pressure are given in the "Sample components and measurement ranges" table. Quantification of dust/particle concentration is necessary in order to determine max OPL. The maximum dust concentration must be checked by ABB Analytical.

Purge gas requirements

The purge gas should not contain any sample gas components and must be oil- and dust-free.

Power supply

Input voltage

24 VDC \pm 5 % from an external power supply unit 115/230 VAC (part of the delivery for general purpose applications)

Power consumption

approx. 20 W

Installation site requirements

The mounting location strongly influences the measurement result. The measurement gas must be well stirred at the selected location to produce a representative measurement result. Stratification in the measurement gas path results in erroneous measurement. If the measurement gas is charged with dust, the LS25 must be mounted at right angles to the process gas flow.

Explosion-proof versions

The AO2000-LS25 Ex analyzer module is suited for use in areas in which explosive atmospheres caused by vapors, gases, mists, or air/dust mixtures are likely to occur.

"Intrinsically optical safe" version for use in zone 2

Designations

 II 3G nA nC [op is Gb] IIC T5 Gc $-20^{\circ}\text{C} \leq T_{\text{amb}} \leq +55^{\circ}\text{C}$
 II 3D tc [op is Gb] IIIC T100°C Dc

Housing protection type

IP66

Version for use in Class 1, Division 2 – CSA

The AO2000-LS25 Ex analyzer module is certified for use in hazardous areas Class 1, Division 2, Groups A, B, C and D, Temperature Code T4, ambient temperature max. +55 °C. Certificate No. 1105720

Laser analyzer module LS25

Gas connections (general purpose application)

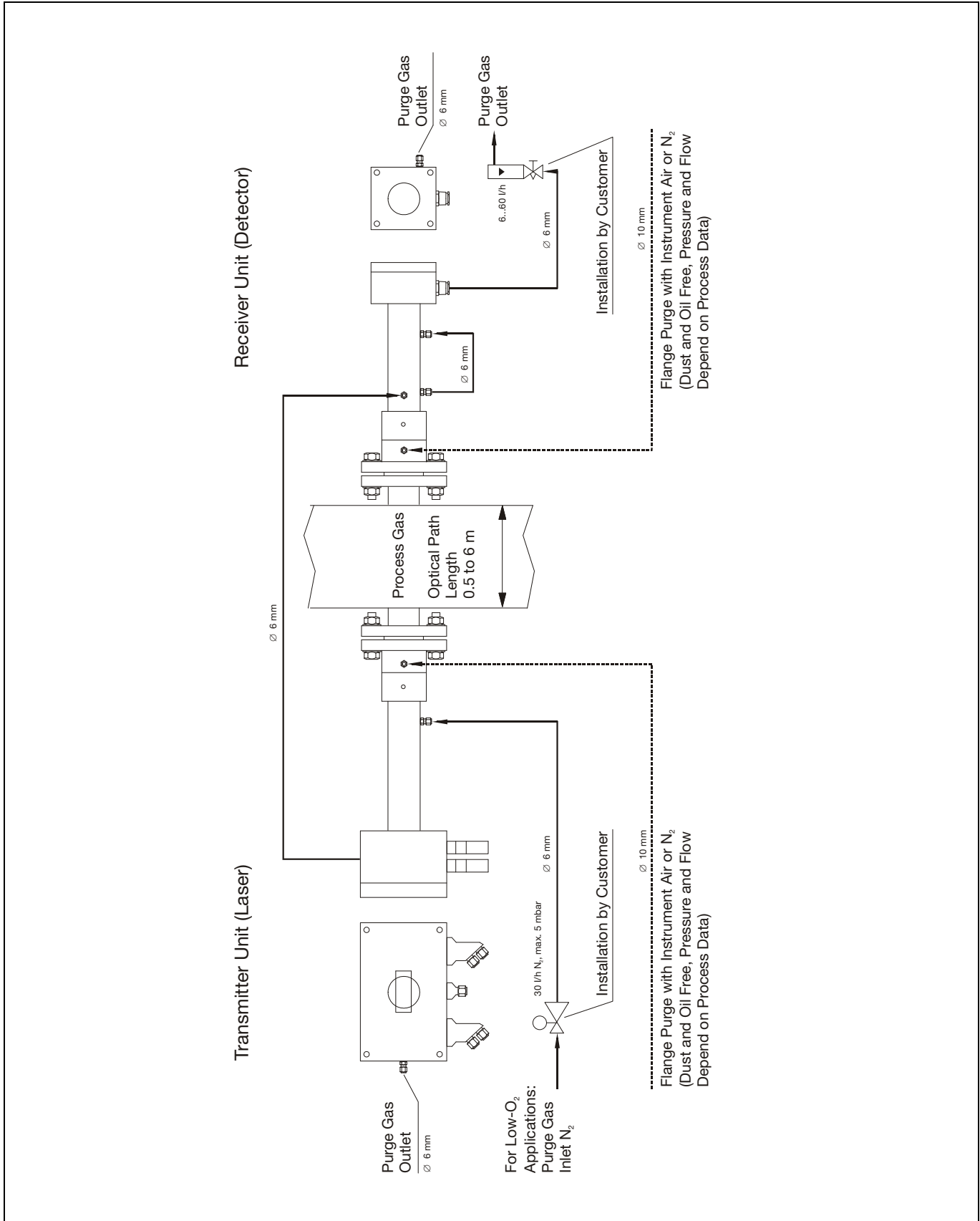

Laser analyzer module LS25

Dimensions and electrical connections (general purpose application)

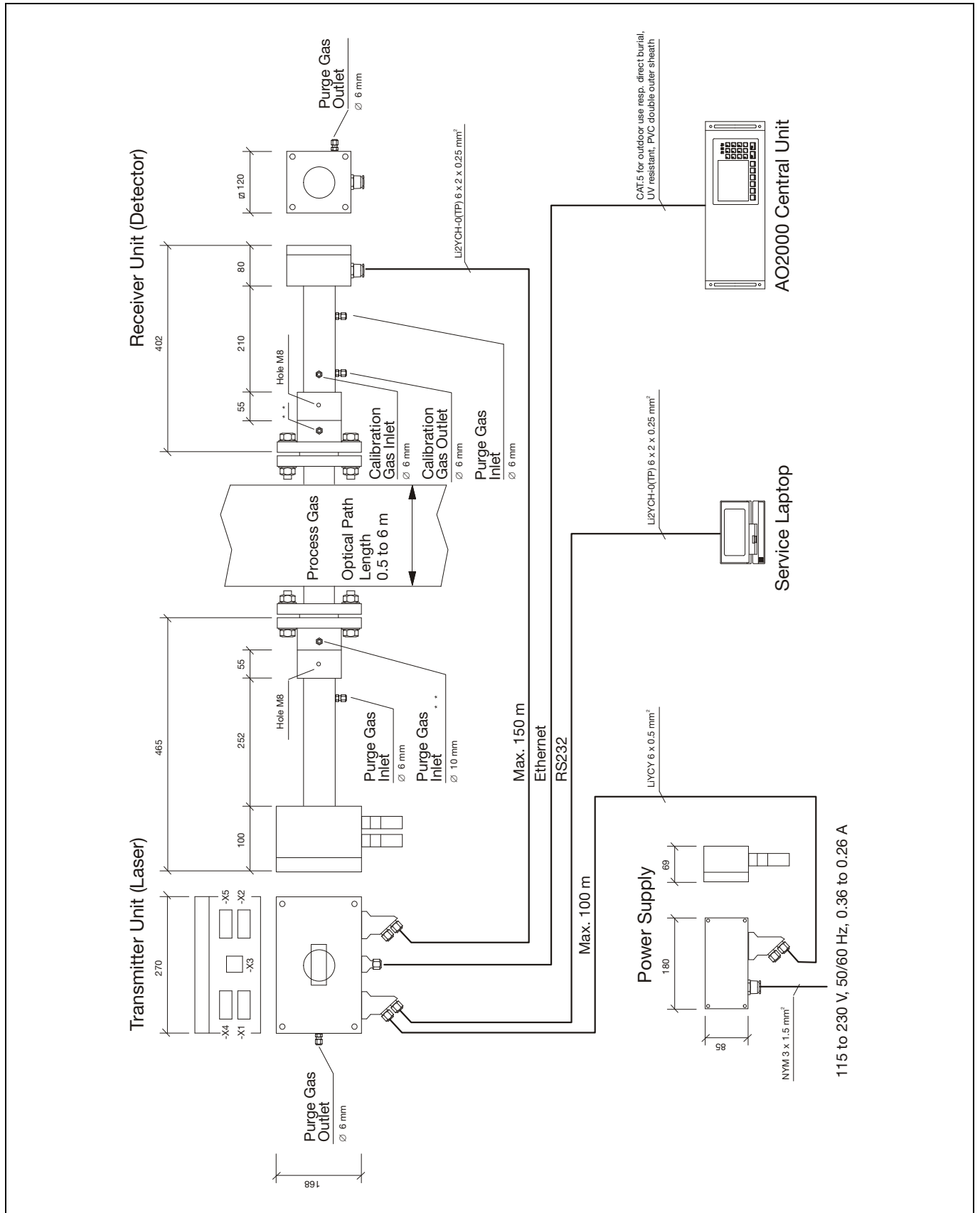

Electrochemical oxygen sensor

Measurement principle

Electrochemical oxygen sensor

Sample component and measurement ranges

Sample component

Oxygen (O₂)

Measurement range quantity and limits

1 to 2 measurement ranges

Adjustable from 0–5 vol.% O₂ to 0–25 vol.% O₂

Measurement range 2

Set to 0–25 vol.% O₂

Stability

Linearity deviation

≤ 1 % of span

Repeatability

≤ 0.5 % of span

Zero drift

Stable over long-term due to absolute zero point

Sensitivity drift

≤ 1 % of the measurement range per week

Output fluctuation (2 σ)

≤ 0.2 % of the measurement range at electronic T90 time

(static/dynamic) = 5/0 sec

Detection limit (4 σ)

≤ 0.4 % of the measurement range at electronic T90 time

(static/dynamic) = 5/0 sec

Influence effects

Flow effect

Flow rate in the 20 to 100 l/h range:

≤ 2 % of the measurement range

Temperature effect

Ambient temperature in permissible range:

≤ 0.2 vol.% O₂ per 10 °C

Air pressure effect

– At zero-point: No effect

– On sensitivity with no pressure correction:

≤ 1 % of the measured value per 1 % air pressure change

– On sensitivity with pressure correction:

≤ 0.2 % of the measured value per 1 % air pressure change

Pressure correction is only possible if the oxygen sensor is connected to an analyzer module with an integral pressure sensor.

Power supply effect

Voltage and frequency in the permissible range: ≤ 0.2 % of

span

Dynamic response

90% response time

T₉₀ ≤ 30 sec, depending on sample gas flow and system layout

Calibration

Zero-point calibration

The oxygen sensor zero is not calibrated since it is fundamentally stable.

End-point calibration

With ambient air at 20.96 vol.% O₂

Materials in contact with the sample medium

Sensor: Polystyrol-ABS, PTFE, FPM

Housing body: PVC-U, FPM seals

Gas ports: Rust- and acid-resistant steel 1.4571 (SAE 316Ti)

Sample gas inlet conditions

The oxygen sensor must not be used for measurement of flammable gases and ignitable gas/air or gas/oxygen mixtures.

Temperature

The sample gas dew point should be at least 5 °C below the ambient temperature throughout the sample gas path. Otherwise a sample gas cooler or condensate trap is required.

Moisture content

H₂O dew point ≥ 2 °C

The oxygen sensor should not be used with dry sample gas.

Inlet pressure

p_e = 2 to 500 hPa

Outlet pressure

Atmospheric pressure

Flow rate

20 to 100 l/h

Associated gas

The oxygen sensor should not be used if the associated gas contains the following components: H₂S, chlorine or fluorine compounds, heavy metals, aerosols, mercaptane, alkaline components.

Notes

The oxygen sensor is always associated with an analyzer module and must be installed in the same housing with that analyzer module.

The oxygen sensor cannot be used with the following analyzer modules:

- Limas21 UV, Limas21 HW, Limas11 IR with stainless steel, PFA or PTFE gas lines
- Fidas24, Fidas24 NMHC
- Analyzer modules for measuring corrosive gases
- Analyzer modules in category 2G

Pneumatics module

Test gas supply

Type

One or three 3/2-way solenoid valves

Power consumption

Approx. 3 W per solenoid valve

Materials in contact with the sample medium

PVDF, FPM, aluminum, stainless steel 1.4305 (SAE 303)

Fine filtration

Type

Disposable filter with borosilicate glass microfiber filter element

Retention rate

99.99 % for particles > 0.1 µm

Materials in contact with the sample medium

Polyamide, borosilicate glass with PVDF binder

Gas supply

Type

Magnetic piston pump

Feed rate

Max. of 60 l/h, depending on analyzer module and inlet/outlet pressure

Flow rate

Adjustable

Power consumption

Approx. 10 W

Materials in contact with the sample medium

PVDF, EPDM, stainless steel 1.4571 (SAE 316Ti)

Flow monitoring

Type

Miniature flow sensor

Readout and limit value monitoring

Configurable

Materials in contact with the sample medium

Al₂O₃, silicon, gold, GFK

Pressure monitoring

Pressure sensor

(Option) for additional monitoring tasks, e.g. pressure measurement in the 2nd gas path of the Uras26 analyzer module

Sample gas inlet conditions

The pneumatics module must not be used for measurement of flammable gases and ignitable gas/air or gas/oxygen mixtures.

Temperature

+5 to +45 °C

The sample gas dew point should be at least 5 °C below the ambient temperature throughout the sample gas path. Otherwise a sample gas cooler or condensate trap is required.

Inlet pressure

$p_e = -80$ to +20 hPa

Flow rate

30 to 60 l/h

Corrosive gases

Corrosive associated gas components and aerosols must be cooled or undergo prior absorption.

Notes

The pneumatics module is always associated with an analyzer module and must be installed in the same housing with that analyzer module.

The pneumatics module cannot be used when stainless steel tubes are used for the internal gas lines.

The pneumatics module cannot be used with the following analyzer modules:

- Limas21 UV, Limas21 HW, Limas11 IR with stainless steel, PFA or PTFE gas lines
- Fidas24, Fidas24 NMHC
- Analyzer modules in category 2G

Explosion protected versions in category 3G

Version in category 3G for measurement of flammable and non-flammable gases (“Safety concept”)

The “safety concept” gas analyzers include:

- Uras26 in the version with safety cell and purged sample cell windows
- Magnos206, Caldos25 and Caldos27 in the version with direct sample cell connection and purged thermostat housing.

Monitoring of the purge gas flow rate is a feature of the “safety concept”. It is fully integrated into the gas analyzer, together with the controls and signal processing.

The version complies with the Directive 2014/34/EU (ATEX directive). There are the following explosion protection measures in the gas analyzer:

- Non-arcing assemblies and components/non-hot components/sealed (arcing) devices per EN 60079-15 and
- Simplified positive pressure containment per EN 60079-2.

Designation

 II 3G Ex nA py II T4 Gc

Housing protection type

IP54

Sample gas inlet conditions

Sample gas

Flammable and non-flammable gases and vapors

- under atmospheric conditions ($p_{\text{abs}} \leq 1.1$ bar, oxygen content ≤ 21 vol.%),
- Temperature class T4,
- not potentially explosive under normal conditions,
- if potentially explosive in the event of a fault, then only seldom and briefly (in accordance with zone 2).

If the sample gas is a mixture only of oxygen and flammable gases and vapors, it must not be explosive under any conditions. As a rule this can be achieved by limiting the oxygen content to a maximum of 2 vol.%.

Flammable gases and vapors that are explosive under the conditions encountered in analysis even when oxygen is excluded should be present in the mixture only in concentrations that are not critical to safety.

Pressure

At sample gas inlet: positive pressure $p_e \leq 3$ hPa,
at sample gas outlet: atmospheric

Flow rate

Max. 40 l/h

Inert gas curtain/purge gas/ (Simplified) pressurized enclosure

Purge gas

Inert gas (nitrogen)

Pressure

Positive operating pressure $p_e \geq$ sample gas pressure + 0.5 hPa

Flow rate

During operation: 15 to 20 l/h, during initial purge: 15 to 50 l/h

Initial purge

Manually controlled, initial purge duration:

Uras26: 1.6 minutes at min. 15 l/h

Magnos206, Caldos25, Caldos27: 18 minutes at min. 15 l/h or 6 minutes at min. 50 l/h

Alarm

When flow rate drops below a minimum value of 15 l/h (corresponds to approx. 7 hPa) and when flow rate exceeds a maximum value of 50 l/h (corresponds to approx. 60 hPa)

Category 3G version for measurement of non-flammable gases

The analyzer modules Uras26, Magnos206, Magnos27, Caldos25 und Caldos27 are suitable for measuring non-flammable gases. The analyzer modules are mounted in the central unit housing or in a separate housing (either wall-mount or 19-inch rack unit).

The version complies with the Directive 2014/34/EU (ATEX directive). The gas analyzer is protected by provisions according to EN 60079-15 (non-arcing electrical equipment, sealed arcing devices).

In undisturbed operation there cannot be any sparking, arcing or impermissible temperatures inside the device. During operation, all unused gas ports should be plugged.

Designation

 II 3G Ex nA nC IIC T4 Gc

Housing protection type

IP54

Explosion protected versions in category 3G

Gas connections “Safety concept”

Uras26

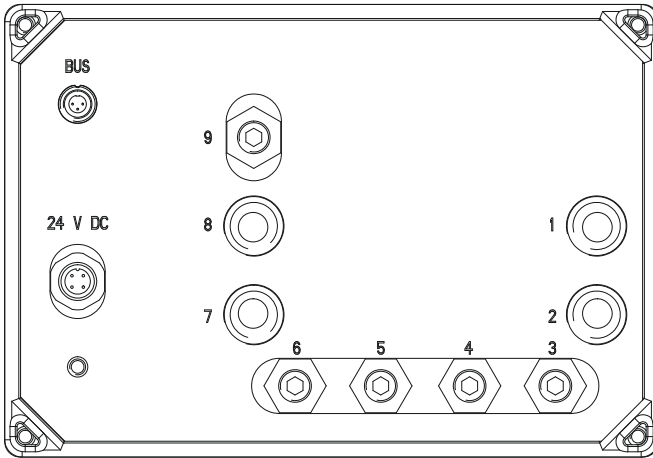

- 1 Sample gas inlet gas path 1
- 2 Sample gas outlet gas path 1
- 3 Purge gas inlet sample cell windows “Analyzer purge in”
- 4 Purge gas inlet housing
- 5 Purge gas outlet housing
- 6 Purge gas outlet flow rate monitor “Analyzer purge out”
- 7 Sample gas outlet gas path 2
- 8 Sample gas inlet gas path 2
- 9 Pressure sensor (option)

Magnos206

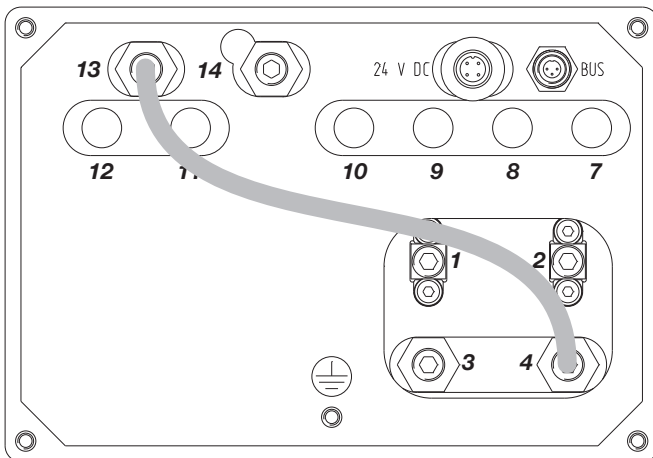

- 1 Sample gas inlet
- 2 Sample gas outlet
- 3 Purge gas inlet thermostat chamber “Analyzer purge in”
- 4 Purge gas outlet thermostat chamber (rigid tubed with 13)
- 7 Purge gas inlet housing
- 8 Purge gas outlet housing
- 9 Pressure sensor 1
- 10 Pressure sensor 2
- 11 not used, sealed
- 12 not used, sealed
- 13 Purge gas inlet flow rate monitor (rigid tubed with 4)
- 14 Purge gas outlet flow rate monitor “Analyzer purge out”

Caldos25, Caldos27

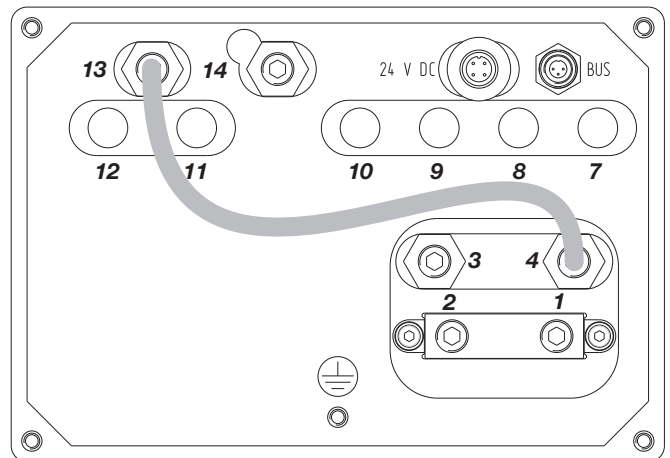

- 1 Sample gas inlet
- 2 Sample gas outlet
- 3 Purge gas inlet thermostat chamber “Analyzer purge in”
- 4 Purge gas outlet thermostat chamber (rigid tubed with 13)
- 7 Purge gas inlet housing
- 8 Purge gas outlet housing
- 9 Pressure sensor 1
- 10 Pressure sensor 2
- 11 not used, sealed
- 12 not used, sealed
- 13 Purge gas inlet flow rate monitor (rigid tubed with 4)
- 14 Purge gas outlet flow rate monitor “Analyzer purge out”

General data

Display and operation

Display

Backlit graphics display, 320 x 240-pixel resolution

Measured value display

Digits with unit and bar graph; simultaneous display of up to 6 measured values, configurable

Units of measure

Selectable in physical units, e.g. ppm, vol.%, mg/m³ or g/m³, as well as in % of span or mA

Digital value resolution

Better than 0.2 % of span

Status indication

Green LED: Power supply on
Yellow LED: Maintenance request
Red LED: Failure

Status messages

Plain text

Operation

Panel with six softkeys, two cancel keys and 10-digit keypad; menu-driven interface, various languages available

Measuring range switch-over and feedback

There are three ways of executing the measuring range switch-over:

- Manually on the gas analyzer
- Automatically (autorange) by means of appropriate configured switch-over thresholds
- Externally controlled via appropriately configured digital inputs.

The measuring range feedback can be implemented via appropriately configured digital outputs; it is independent of the selected type of measuring range switch-over.

Limit value monitoring

Limit values can be set during the gas analyzer configuration. The limit value signals (alarms) are output via digital outputs.

Housing

Versions

19-inch housing (model AO2020) or
Wall-mount housing (model AO2040)

Housing protection type

IP65 without power supply and without display/control unit
IP54 with display/control unit and connection box
IP20 without connection box per EN 60529

Housing purge

Possible with IP54 version with connection box. Purge version can be fitted with screwed cable glands (per EN) or with conduit connections (per CSA). Purge gas flow during operation max. 20 l/h (Fidas24, Fidas24 NMHC: approx. 300 l/h), purge gas pressure $p_a = 2$ to 4 hPa. The purge gas should not contain any sample gas components.

Housing materials

Housing: stainless steel 1.4016 (SAE 430), module rear panel: aluminum, keypad sheet: Polyester

Housing color

Light gray (RAL 7035), basalt gray (RAL 7012)

Weight

Analyzer unit with one analyzer module: 18 to 23 kg

Dimensions

See dimensional drawings on page 42 and page 43

Gas connections

Layout

Gas ports on back (19-inch rack housing) or bottom (wall-mount housing) of the analyzer module

Design

1/8 NPT internal threads for commercially available adapters, e.g. Swagelok®, unless other versions are specified in the technical data of the individual analyzer modules.

Electrical connections

Central unit

Power supply: 3-pin plug per EN 60320/C14, connecting cable supplied;
Ethernet: Two 8-pin RJ45 plugs;
System bus: 3-pin female plug

Analyzer modules

External power supply: 4-pin male plug;
Heating of detector and sample gas inlet (FID analyzer modules): 4-pin male plug, connecting cable supplied;
System bus: 3-pin female plug

Electrical safety

Tested per EN 61010-1:2010

Protection class

I for central unit with electronics module (power supply);
III for analyzer modules without electronics module (power supply)

Overvoltage category/pollution degree

Power supply: II/2

Safe isolation

The power supply is galvanically isolated from other circuits by means of reinforced or double insulation. Protective extra-low voltage (PELV) on low-voltage side

Electromagnetic compatibility

Noise immunity

Tested per EN 61326-1:2013.
Inspection severity: Industrial area, fulfills at least the rating "continuously monitored operation" to table 2 of EN 61326.

Emitted interference

Tested per EN 61326-1:2013.
Limit value class B for interference field strength and interference voltage is met.

Mechanical stress

Transport

Vibration test per EN 60068-2-6:1996.
Shock test per EN 60068-2-27:1995.
In its original packaging, the gas analyzer will withstand normal shipping conditions.

General data

Installation site requirements

Installation location

The gas analyzer is intended for indoor installation only.
Altitude above 2000 m on request.

Vibration

Analyzer unit only:

Uras26:	Max. ± 0.04 mm at 5 to 55 Hz, 0.5 g at 55 to 150 Hz, slight transient effect on sample value in the region of the beam modulation frequency
Limas21 UV, Limas11 IR:	Max. ± 0.04 mm at 5 to 55 Hz, 0.5 g at 55 to 150 Hz
Limas21 HW:	Max. ± 0.04 mm/0.5 g at 5 to 150 Hz
Magnos206:	Max. ± 0.04 mm at 5 to 20 Hz
Magnos27:	Max. ± 0.04 mm at 5 to 60 Hz
ZO23:	Max. ± 0.04 mm at 5 to 55 Hz, 0.5 g at 55 to 150 Hz
Caldos25:	Max. ± 0.04 mm at 5 to 30 Hz
Caldos27:	Max. ± 0.04 mm at 5 to 55 Hz, 0.5 g at 55 to 150 Hz
Fidas24:	Max. 0.5 g, max. 150 Hz
Fidas24 NMHC:	Max. 0.5 g, max. 150 Hz
LS25:	Max. ± 0.6 mm around the optical axis, max. 500 Hz

Analyzer unit installed in cabinet (analyzer system): Max. acceleration 0.01 ms^{-2} in a frequency range of 0.1 to 200 Hz. Compliance with the metrological data can only be assured if data on vibration amplitude and frequency range at the installation site are available and suitable means are employed to decouple the analyzer.

Ambient temperature

Operation:	When installed in housing with electronics module	without electronics module
Uras26:	+5 to +40 °C	+5 to +45 °C
Limas21 UV, Limas11 IR:	+5 to +40/45 °C with / w/o I/O cards	+5 to +45 °C
Limas21 HW:	+15 to +35 °C	+15 to +35 °C
Magnos206:	+5 to +45 °C	+5 to +50 °C
Magnos27:	+5 to +45 °C	+5 to +45 °C, +5 to +50 °C with direct sample cell connection and when installed in housing without Uras26
ZO23:	+5 to +45 °C	+5 to +45 °C
Caldos25:	+5 to +45 °C	+5 to +45 °C
Caldos27:	+5 to +45 °C	+5 to +50 °C
Fidas24:	+5 to +45 °C	+5 to +45 °C
Fidas24 NMHC:	+5 to +40 °C	+5 to +40 °C
LS25:	-20 to +55 °C, no direct solar irradiation	
Oxygen sensor:	+5 to +40 °C in 19-inch housing, +5 to +35 °C in wall-mount housing	
Central unit without analyzer module:	+5 to +55 °C	
Storage and transport:	-25 to +65 °C, oxygen sensor: -20 to +60 °C	

Relative humidity

< 75 %, no condensation

Climate class

3K3 for IP20 housing (non-condensing),
3K4 for IP54 housing (condensing) per EN 60721-3-3

Air circulation

For sufficient air circulation, multiple housings in a 19-inch rack must be installed with a separation of at least one height unit between housings.

Power supply

Power supply unit

Input voltage

100 to 240 VAC, -15 %, +10 %, max. 2.2 A, 50 to 60 Hz \pm 3 Hz

Power consumption

Max. 187 VA

Output voltage

24 VDC \pm 5 % to supply the electronics module (see page 38) and one analyzer module installed in the central unit or (optionally) one external analyzer module

Fidas24, Fidas24 NMHC:

Heating of detector and sample gas inlet

Input voltage

115 VAC or 230 VAC, \pm 15 % (max. 250 VAC), 47 to 63 Hz

Power consumption

Fidas24:	125 VA for detector
	125 VA for sample gas inlet (option)
Fidas24 NMHC:	Approx. 200 VA for detector
	125 VA for sample gas inlet (option)

Analyzer modules

Input voltage

24 VDC \pm 5 %

Power consumption

Uras26:	Max. 95 W
Limas21 UV, Limas11 IR:	Max. 100 W
Limas21 HW:	Max. 100 W
Magnos206:	Max. 50 W
Magnos27:	Max. 35 W
ZO23:	Approx. 12 W in continuous operation, approx. 35 W during start-up
Caldos25:	Max. 25 W
Caldos27:	Max. 12 W
Fidas24:	Max. 40 W
Fidas24 NMHC:	Max. 40 W
LS25:	Approx. 20 W

Note regarding the analyzer module performance characteristics

The analyzer module performance characteristics indicated apply only when operated in conjunction with the central unit. They have been determined according to IEC 61207-1:2010 "Expression of performance of gas analyzers – Part 1: General". They are based on operation at atmospheric pressure (1013 hPa) and nitrogen as the associated gas. Compliance with these characteristics when measuring other gas mixtures can only be assured if their composition is known.

Electronics module

Processing of measured values and signals

Processor system with buffered real-time clock and non-volatile memory for firmware and device data.

Software updates can be obtained via the Ethernet interface.

I/O modules

Number of Slots

5 slots (see “Electrical connections”)

Technical data

see pages 39 to 41

Notes regarding conductor section

- The maximum capacity of terminals for stranded or solid conductors is 1 mm² (17 AWG).
- The stranded conductor may be tinned on the tip or twisted for simplified connection.
- When using wire end ferrules the total section should not exceed 1 mm², i.e. the maximum stranded conductor section is 0.5 mm². The Weidmüller PZ 6/5 crimping tool must be used for crimping the ferrules.

Electrical connections

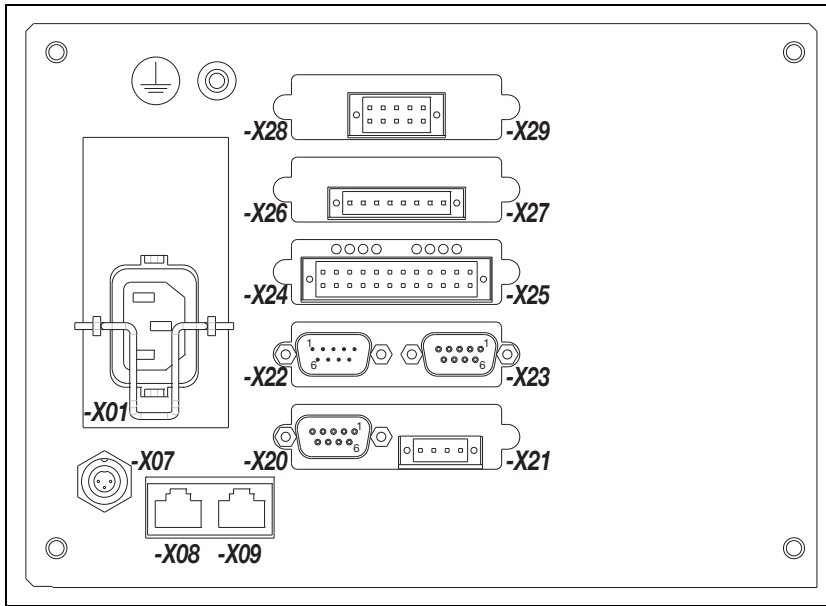

- X01 Power supply connection
 - X07 System bus connection
 - X08, Ethernet 10/100/1000BASE-T interfaces
 - X09
 - X20 I/O modules (5 slots), options:
 - to – Profibus module
 - X29 – Modbus module
 - Digital I/O module
 - 2-way analog output module
 - 4-way analog output module
 - 4-way analog input module
- Connection diagrams see pages 39 to 41

Note:

The drawing shows an example for the I/O modules equipment.

Interfaces

Ethernet

To connect the gas analyzer to Ethernet networks. TCP/IP protocol and Modbus TCP/IP protocol via 10/100/1000BASE-T interface.

Electrical connections: Two 8-pin RJ45 plugs

System bus

Internal bus for communication between the gas analyzer's functional units.

Electrical connections: 3-pin female plug

Power supply

Input voltage

24 VDC ± 5 % from the built-in power supply (see page 37)

Power consumption

approx. 15 W without I/O modules

I/O modules

Profibus module

Application

Integration of AO2000 into PROFIBUS PA and PROFIBUS DP networks for transfer of measured values and status signals as well as analog inputs, digital inputs and digital outputs. Digital data transmission certified according to guideline VDI 4201, Sheets 1 and 2.

Electrical connections

RS485 interface:

- 1 – not used
- 2 M24 24 V output ground, max. 0.2 A
- 3 RxD/TxD-P Receive/transmit data plus, B-line
- 4 – not used
- 5 DGND Data transmission potential (Ref. pot. for VP)
- 6 VP Supply voltage plus (5 V)
- 7 P24 24 V output voltage plus
- 8 RxD/TxD-N Receive/transmit data N, A-line
- 9 – not used

Design: 9-pin Sub-D female connector

MBP interface (non-intrinsically safe):

- 1 +
- 2 Shield
- 3 –
- 4 not used

Design: 4-pin terminal strip. Observe the information regarding conductor section (see page 38).

Connection diagram

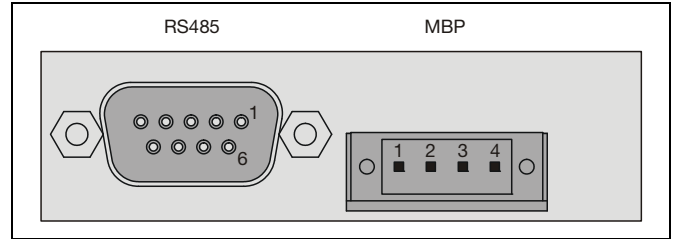

Modbus module

Application

Transfers measured values and status signals as well as analog inputs, digital inputs and digital outputs to host systems, e.g. to standard Windows applications via M-DDE Server; Modbus slave protocol in RTU (remote terminal unit) mode or via RS485 or RS232 interface (configurable).

Electrical connections

RS232 interface:

- 2 RxD
- 3 TxD
- 5 GND

Design:

9-pin Sub-D male connector

RS485 interface:

- 2 RTxD-
- 3 RTxD+
- 5 GND

Design:

9-pin Sub-D female connector

Connection diagram

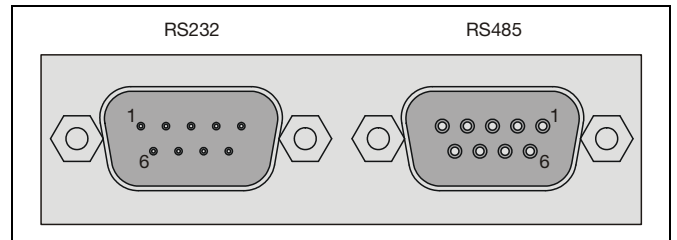

I/O modules

Digital I/O module

4 Digital inputs (DI1 to DI4)

Optocouplers with internal 24 VDC power supply, jointly galvanically isolated from ground. Control with floating contacts, with external voltage 12 to 24 VDC or with open collector drivers PNP or NPN.

4 Digital outputs (DO1 to DO4)

Floating double-throw contacts, max. contact load rating 30 VDC/1 A, galvanically isolated from ground. Relays must at all times be operated within the specified data range. Inductive or capacitive loads are to be connected with suitable protective measures (self-induction recuperation diodes for inductive loads and series resistors for capacitive loads).

Standard function block applications

Status signals/externally controlled calibration:

- DO1 Failure/collective status
- DO2 Maintenance mode/limit value
- DO3 Maintenance request/limit value
- DO4 External solenoid valve
- DI1 Start automatic calibration
- DI2 Inhibit automatic calibration
- DI3 Calibrate zero-point
- DI4 Calibrate end-point

Measurement range control:

- DO1 Measurement range feedback
- DO2 Measurement range feedback
- DO3 Measurement range feedback
- DO4 Measurement range feedback
- DI1 Measurement range switchover
- DI2 Measurement range switchover
- DI3 Measurement range switchover
- DI4 Measurement range switchover

Limit values:

- DO1 Limit value
- DO2 Limit value
- DO3 Limit value
- DO4 Limit value
- DI1 Calibration cells in/out
- DI2 Hold current output
- DI3 Pump on/off
- DI4 External failure

Calibration control:

- DO1 External solenoid valve sample gas
- DO2 External solenoid valve zero gas
- DO3 External solenoid valve span gas
- DO4 External pump on/off
- DI1 Pump on/off
- DI2 External failure
- DI3 External failure
- DI4 External failure

Electrical connections

See connection diagram

Design: 2x12-pin terminal strip. Observe the information regarding conductor section (see page 38).

The pin layout in a delivered gas analyzer will be shown in the applicable "Analyzer data sheet".

Relays are shown in the unpowered state. The unpowered state is the failure mode.

Connection diagram

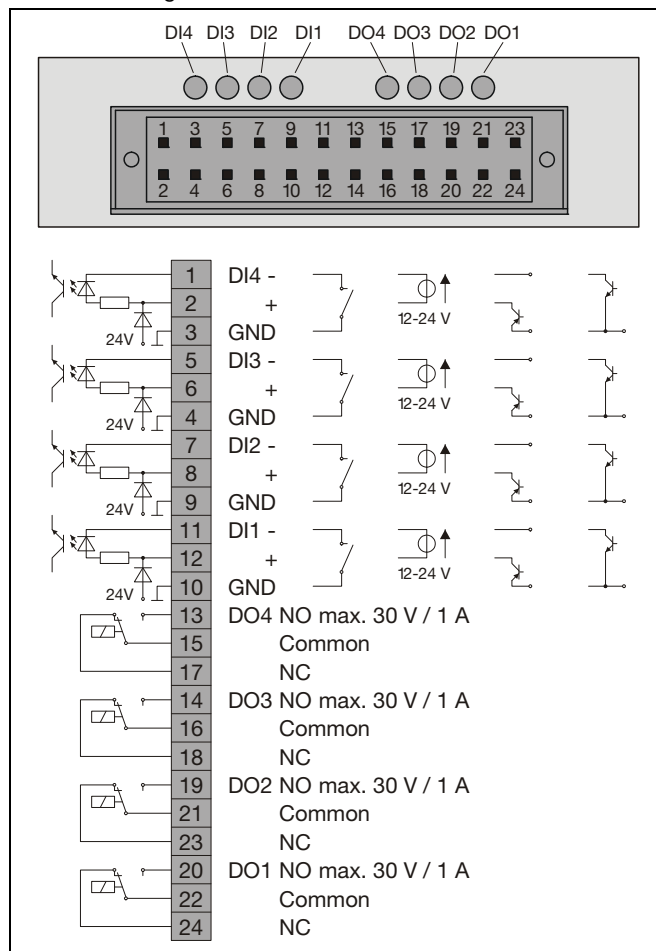

I/O modules

2-way analog output module

2 analog outputs (AO1, AO2)

0/4 to 20 mA (configurable, factory-set to 4 to 20 mA), common negative pole, galvanically isolated from ground, freely connectable to ground, max. gain relative to protective ground potential 50 V, max. working resistance 750 Ω. Resolution 16 bit. The output signal cannot be lower than 0 mA.

Electrical connections

See connection diagram

Design: 4-pin terminal strip. Observe the information regarding conductor section (see page 38).

The pin layout in a delivered gas analyzer will be shown in the applicable "Analyzer data sheet".

Connection diagram

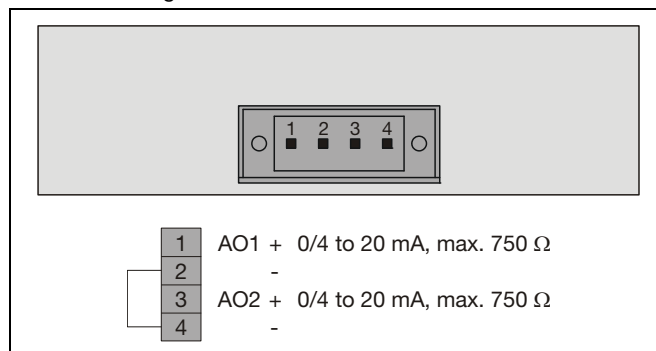

4-way analog output module

4 analog outputs (AO1 to AO4)

0/4 to 20 mA (configurable, factory-set to 4 to 20 mA), common negative pole, galvanically isolated from ground, freely connectable to ground, max. gain relative to protective ground potential 50 V, max. working resistance 750 Ω. Resolution 16 bit. The output signal cannot be lower than 0 mA.

Electrical connections

See connection diagram

Design: 8-pin terminal strip. Observe the information regarding conductor section (see page 38).

The pin layout in a delivered gas analyzer will be shown in the applicable "Analyzer data sheet".

Connection diagram

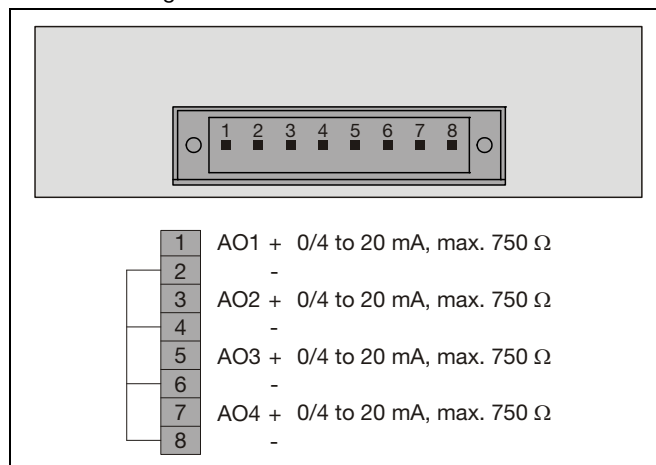

4-way analog input module

4 analog inputs (AI1 to AI4)

0 to 20 mA into 50 Ω, jointly galvanically isolated from ground.

Current output

+24 VDC for supply of an external sensor, fused with 100 mA (resettable fuse)

Electrical connections

See connection diagram

Design: 2x5-pin terminal strip. Observe the information regarding conductor section (see page 38).

The pin layout in a delivered gas analyzer will be shown in the applicable "Analyzer data sheet".

Connection diagram

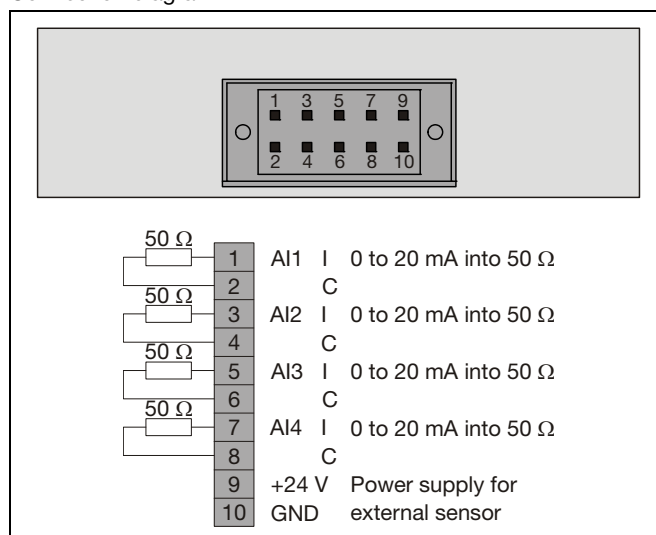

Dimensional drawings

19-inch rack housing (model AO2020)

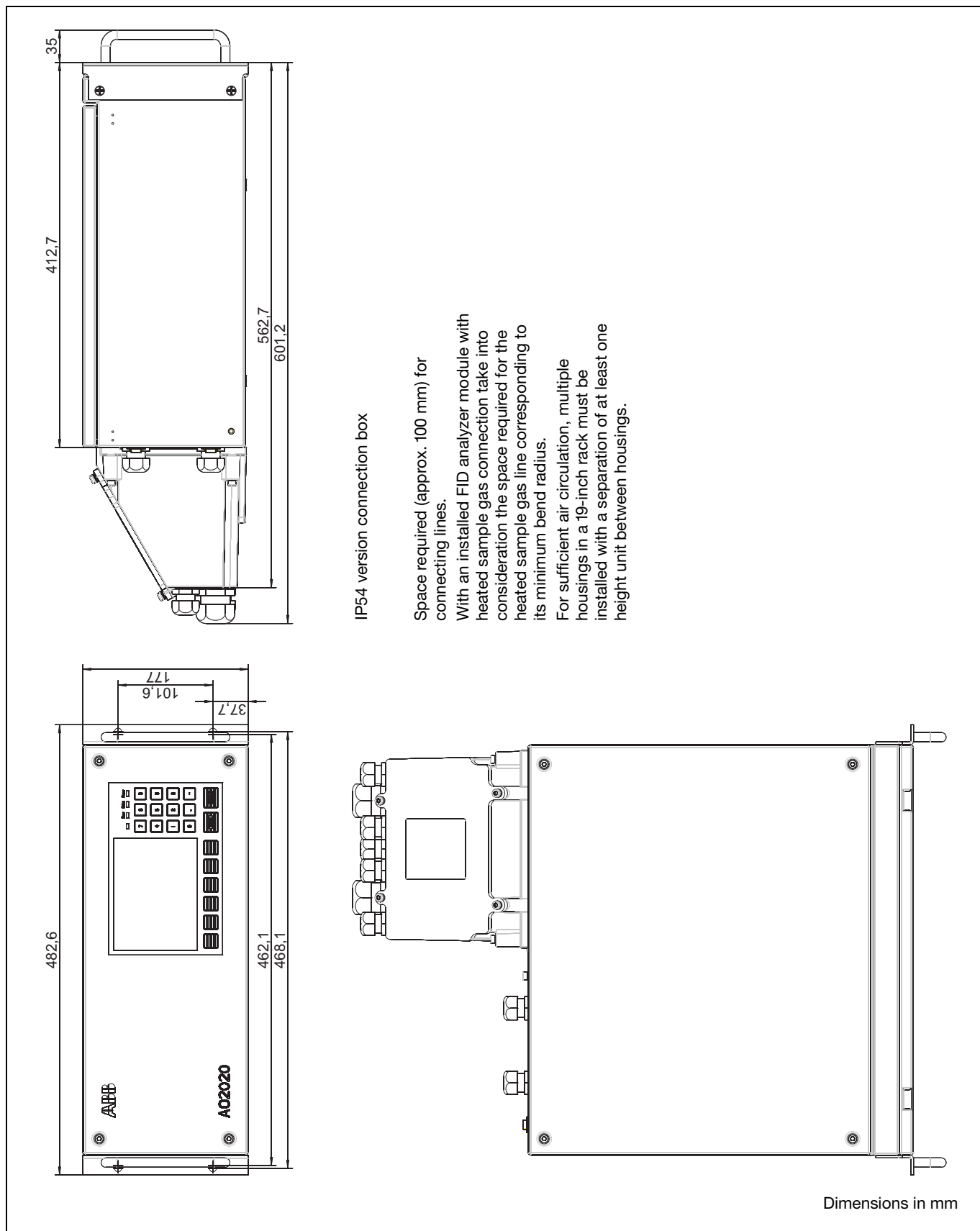

IP54 version connection box

Space required (approx. 100 mm) for connecting lines.

With an installed FID analyzer module with heated sample gas connection take into consideration the space required for the heated sample gas line corresponding to its minimum bend radius.

For sufficient air circulation, multiple housings in a 19-inch rack must be installed with a separation of at least one height unit between housings.

Dimensions in mm

Dimensional drawings

Wall-mount housing (model AO2040)

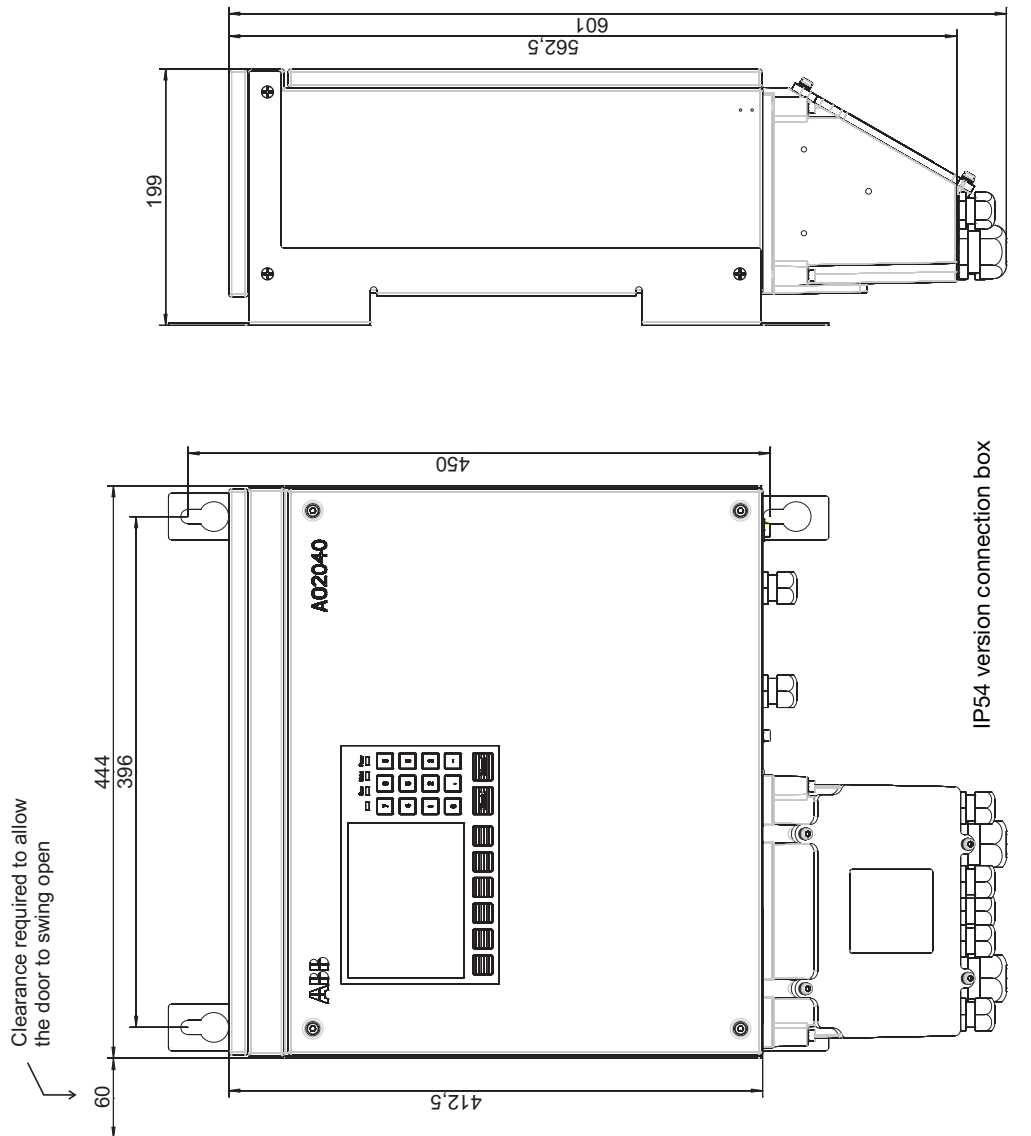

Space required (approx. 100 mm) for connecting lines.
 With an installed FID analyzer module with heated sample gas connection take into consideration the space required for the heated sample gas line corresponding to its minimum bend radius.
 With an installed FID analyzer module additional clearance (approx. 300 mm) is required since some assemblies can only be accessed from above.

Dimensions in mm

Certifications

Performance tests

The AO2000 Series gas analyzers Uras26 (sample components CO, NO, SO₂, CO₂, N₂O), Magnos206 (sample component O₂) and electrochemical oxygen sensor (sample component O₂) are certified for use in facilities requiring approval according to European directives 2001/80/EG and 2000/76/EG and meet the requirements of the 27th/30th BImSchV (German Federal Immissions Control Ordinance) and TA-Luft (German Technical Instructions on Air Quality) regulations. The requirements of QAL1 according to EN 15267 and EN 14181 are fulfilled.

Report No. 821029 of June 30, 2006. Notification: Federal Gazette of October 14, 2006, No. 194, page 6715

Report No. 1249694 of March 30, 2009. Notification: Federal Gazette of August 25, 2009, No. 125, page 2932.

Report No. 1710933 of September 30, 2011. Notification: Federal Gazette of March 2, 2012, No. 36, page 923.

Report No. 936/21217137/A of October 14, 2011. Notification: Federal Gazette of March 2, 2012, No. 36, page 922.

Report No. 1958844 of August 30, 2013. Notification: Federal Gazette AT of April 01, 2014, No. B12, page 15.

The AO2000 Series gas analyzers Limas21 UV (sample components NO, NO₂, SO₂) and electrochemical oxygen sensor (sample component O₂) are certified for use in facilities requiring approval according to European directives 2001/80/EG and 2000/76/EG and meet the requirements of the TA-Luft (German Technical Instructions on Air Quality) regulations. The requirements of QAL1 according to EN 15267 and EN 14181 are fulfilled.

Report No. 2231669.1 of September 1, 2015. Notification: Federal Gazette AT of March 14, 2016, No. B7, page 2.

The AO2000 Series gas analyzer Fidas24 (sample component C-total) is certified for use in facilities requiring approval (13th BImSchV, 17th BImSchV, 30th BImSchV, TA-Luft – German Technical Instructions on Air Quality) and in facilities of 27th BImSchV (German Federal Immissions Control Ordinance). The requirements of QAL1 according to EN 15267 and EN 14181 are fulfilled.

Report No. 936/21228173/A of October 21, 2015. Notification: Federal Gazette AT of March 14, 2016, No. B7, page 2.

The AO2000 Series gas analyzer Uras26 (sample components SO₂ und CO₂) is certified for use on vessels. The requirements of MEPC.184(59) and MEPC.259(68), Chapter 6 “Emission Testing” as well as the relevant requirements of Revised MARPOL Annex VI and NO_x Technical Code 2008 are fulfilled.

Certificate No. 30652-15 HH of November 27, 2015

The AO2000 Series gas analyzer Limas21 UV (sample components NO, NO₂ und NO_x) is certified for use on vessels. The requirements of Revised MARPOL Annex VI and NO_x Technical Code 2008 are fulfilled.

Certificate No. 31812-16 HH of October 13, 2016

CE conformity

The AO2000 Series gas analyzers satisfy the requirements of the European directives

2014/35/EU Low Voltage Directive,

2014/30/EU EMC Directive and

2014/34/EU ATEX Directive (explosion protected versions only).

Approval for USA and Canada – CSA

The AO2000 series gas analyzers are certified for use in general purpose environment, evidenced by full compliance with standards CAN/CSA-C22.2 No. 61010-1-04 and UL Std. No. 61010-1 (2nd Edition).

Certificate No. 2397390

The AO2000 Series gas analyzers Lima21 UV, Limas21 HW and Limas11 IR are certified for use in general purpose environment, evidenced by full compliance with standards CAN/CSA-C22.2 No. 61010-1-12 and UL Std. No. 61010-1 (3rd Edition).

Certificate No. 70012655

Approval for the customs union of Russia, Belarus and Kazakhstan – GOST TR CU

The AO2000 Series gas analyzers are certified for use in general purpose environment.

GOST TR CU certificate No. TC N RU Д-DE.AB72.B.02310

Pattern approval certificate for Russia No. DE.C.31.004.A

No. 37985.

Certifications

Explosion protection to European standards

The AO2000 Series gas analyzers with Uras26, Magnos206, Caldos25 and Caldos27 in category 3G for measurement of flammable and non-flammable sample gas (“safety concept”) satisfy the European standards EN 60079-15:2010, EN 60079-2, EN 60664-1:2007

Designation:

 II 3G Ex nA py II T4 Gc

The AO2000 Series gas analyzers with Uras26, Magnos206, Magnos27, Caldos25 and Caldos27 in category 3G for measurement of non-flammable sample gas satisfy the European standard EN 60079-15:2010, EN 60664-1:2007.

Designation:

 II 3G Ex nA nC IIC T4 Gc

The LS25 analyzer module for use in zone 2 satisfies the European standards EN 60079-0:2012, EN 60079-15:2010, EN 60079-28:2007, EN 60079-31:2014.

Designations:

 II 3G nA nC [op is Gb] IIC T5 Gc $-20^{\circ}\text{C} \leq T_{\text{amb}} \leq +55^{\circ}\text{C}$,

 II 3D tc [op is Gb] IIIC T100°C Dc

Explosion protection to U.S. and Canadian standards – CSA

The AO2000 Series gas analyzers are certified for use in Class 1, Div. 2, Groups A, B, C, and D, Temperature code T4, ambient temperature max. +50 °C (+55 °C for LS25) explosion hazard areas.

Housing versions not equipped with conduit entries must be installed in a suitable enclosure, cabinet or rack with provision for connection of Div. 2 wiring methods, acceptable to the local inspection authority having jurisdiction.

Certificate No. 1105720

Explosion protection for the customs union of Russia, Belarus and Kazakhstan – GOST TR CU

The AO2000 Series gas analyzers in the “safety concept” version are certified for use in Zone 2 environment.

Certificate No. TC RU C-DE.ГБ04.B.00278

Explosion protection for South Korea – KCs

The AO2000 Series gas analyzers with Uras26, Magnos206, Caldos25 and Caldos27 are certified for use in hazardous locations. They may be used for measurement of flammable gases and vapors.

Designation: Ex nA py II T4

Certificate No. 16-GA4BO-0670X

Sample components and analyzer modules

The following table lists the sample components that can be measured with the AO2000 Series gas analyzers (other sample components available on request).

In each case, the smallest measurement range and the appropriate analyzer module are given. Please see the data of the individual analyzer modules.

Sample component	Requirements (examples)	Smallest meas. range	Analyzer module	Data	
Acetylene	C ₂ H ₂	Small meas. ranges, selective measurement	Uras26	Page 4	
		Flammable gases, selective measurement	Limas11 IR	Page 10	
Ammonia	NH ₃	Process measurement	Uras26	Page 4	
		Combustion exhaust gas	Limas21 HW	Page 8	
Argon	Ar in N ₂	Especially short T ₉₀ time	97.5–100 vol. %	Caldos27	Page 22
	Ar in O ₂	Especially short T ₉₀ time	0–2 vol. %	Caldos27	Page 22
Butane	C ₄ H ₁₀	Small meas. ranges, selective measurement	Uras26	Page 4	
		Flammable gases, selective measurement	Limas11 IR	Page 10	
Chlorine	Cl ₂	Corrosive gases	0–100 ppm	Limas21 UV	Page 6
Nitrous oxide	N ₂ O	Small measurement ranges	0–20 ppm	Uras26	Page 4
Ethane	C ₂ H ₆	Small meas. ranges, selective measurement	Uras26	Page 4	
		Flammable gases, selective measurement	Limas11 IR	Page 10	
Ethylene	C ₂ H ₄	Small meas. ranges, selective measurement	0–300 ppm	Uras26	Page 4
		Flammable gases, selective measurement	0–1500 ppm	Limas11 IR	Page 10
Helium	He in N ₂	Especially short T ₉₀ time	97–100 vol. %	Caldos27	Page 22
Hexane	C ₆ H ₁₄	Selective measurement	0–100 ppm	Uras26	Page 4
Refrigerant	R 134a	Small measurement ranges	0–50 ppm	Uras26	Page 4
Carbon dioxide	CO ₂	Small measurement ranges	0–5 ppm	Uras26	Page 4
		Corrosive/toxic/flammable gases	0–150 ppm	Limas11 IR	Page 10
		Especially short T ₉₀ time	0–3 vol. %	Caldos27	Page 22
Carbon disulfide	CS ₂	Toxic/flammable gases	0–50 ppm	Limas21 UV	Page 6
Carbon monoxide	CO	Small meas. ranges, emission measurement	0–10 ppm	Uras26	Page 4
		Toxic/flammable gases, process measurement	0–500 ppm	Limas11 IR	Page 10
Carbon oxide Sulfide	COS	Toxic/flammable gases	0–250 ppm	Limas21 UV	Page 6
Hydrocarbons	Total	Fast hot measurement	0–5 mg C/m ³	Fidas24	Page 24
	C _n H _m – CH ₄	Non-methane measurement	0–5 mg C/m ³	Fidas24 NMHC	Page 26
Methane	CH ₄	Small meas. ranges, selective measurement	0–50 ppm	Uras26	Page 4
		Flammable gases, selective measurement	0–1000 ppm	Limas11 IR	Page 10
		Especially short T ₉₀ time	99–100 vol. %	Caldos27	Page 22
	CH ₄ in N ₂	Especially short T ₉₀ time	0–2 vol. %	Caldos27	Page 22
Propane	C ₃ H ₈	Small meas. ranges, selective measurement	0–50 ppm	Uras26	Page 4
		Flammable gases, selective measurement	0–150 ppm	Limas11 IR	Page 10
Propylene	C ₃ H ₆	Small meas. ranges, selective measurement	0–100 ppm	Uras26	Page 4
		Flammable gases, selective measurement	0–500 ppm	Limas11 IR	Page 10
Hydrochloric acid	HCl	Corrosive gases	0–2500 ppm	Limas11 IR	Page 10
Oxygen	O ₂	Magnetomechanical measurement principle	0–0.5 vol. %	Magnos206	Page 14
		Trace measurement with ZrO ₂ cell	0–1 ppm	ZO23	Page 18
		Electrochemical measurement principle	0–5 vol. %	Oxygen sensor	Page 32
	O ₂ in N ₂	Thermomagnetic measurement principle	0–3 vol. %	Magnos27	Page 16
	O ₂ in flue gas	Thermomagnetic measurement principle	0–3 vol. %	Magnos27	Page 16
Sulfur dioxide	SO ₂	Emission measurement	0–25 ppm	Uras26	Page 4
		Corrosive gases	0–25 ppm	Limas21 UV	Page 6
		Corrosive gases	0–1.5 vol. %	Caldos25	Page 20
Hydrogen Sulfide	H ₂ S	Exhaust gas, process measurement	0–25 ppm	Limas21 UV	Page 6
Nitrogen dioxide	NO ₂	Corrosive gases	0–50 ppm	Limas21 UV	Page 6
		Combustion exhaust gas	0–10 ppm	Limas21 HW	Page 8
Nitrogen monoxide	NO	Emission measurement	0–75 ppm	Uras26	Page 4
		Small measurement ranges	0–10 ppm	Limas21 UV	Page 6
		Combustion exhaust gas	0–10 ppm	Limas21 HW	Page 8
Hydrogen	H ₂ in Ar	Especially short T ₉₀ time	0–0.25 vol. %	Caldos27	Page 22
	H ₂ in Cl ₂	Corrosive gases	0–0.5 vol. %	Caldos25	Page 20
	H ₂ in stack gas	Especially short T ₉₀ time	0–0.5 vol. %	Caldos27	Page 22
	H ₂ in N ₂	Especially short T ₉₀ time	99–100 vol. %	Caldos27	Page 22
	H ₂ in N ₂ or air	Corrosive gases	0–0.5 vol. %	Caldos25	Page 20
		Especially short T ₉₀ time	0–0.3 vol. %	Caldos27	Page 22

Notes

Contact us

ABB Limited

Process Automation

Oldends Lane
GL10 3TA Stonehouse
Gloucestershire, United Kingdom
Phone: +44 1 453 826661
Fax: +44 1 453 829671

ABB Pte. Ltd.

Process Automation

2 Ayer Rajah Crescent
139935 Singapore, Singapore
Phone: +65 6773 5961
Fax: +65 6778 0222

ABB Engineering Ltd.

Process Automation

10 Jiuxianqiao Lu
100015 Beijing, China
Phone: +86 10 84566688 Ext. 6217
Fax: +86 10 84567650

ABB Inc.

Process Automation

3700 W Sam Houston Parkway South,
Suite 600, Houston, TX 77042, USA
Phone: +1 713 587 8000

www.abb.com/analytical

ABB Australia Pty Limited

Process Automation

Bapaume Road
2170 Moorebank
New South Wales, Australia
Phone: +61 2 9821 0968
Fax: +61 2 9400 7050

ABB Ltd.

Process Automation

14 Mathura Road
121003 Faridabad, Haryana, India
Phone: +91 129 2279627
Fax: +91 129 2279692

ABB Automation GmbH

Process Automation

Stierstaedter Strasse 5
60488 Frankfurt am Main, Germany
Fax: +49 69 7930-4566
E-mail: cga@de.abb.com

Note

We reserve the right to make technical changes or modify the contents of this document without prior notice. With regard to purchase orders, the agreed particulars shall prevail. ABB does not accept any responsibility whatsoever for potential errors or possible lack of information in this document.

We reserve all rights in this document and in the subject matter and illustrations contained therein. Any reproduction, disclosure to third parties or utilization of its contents – in whole or in parts – is forbidden without prior written consent of ABB.

Copyright© 2016 ABB
All rights reserved



Sales



Service