

Multiple Spot Thermometers - MST

BENEFITS

- Custody Transfer Accuracy
- Highest reliability
- Rugged design for harsh environments
- Anchor weights, flanges, vapor boots & junction boxes can be included
- Version with integrated water level sensor is available
- Easy integration in TankRadar Rex Inventory Tank Gauging System

Product temperature is one of the prime parameters for custody transfer and accurate inventory measurement in liquid bulk storage tanks.

Rosemount Tank Gauging offers the Multiple Spot Thermometer (MST) for accurate and reliable measuring of temperature.

The Multiple Spot Thermometer (MST) is designed to measure the temperature of bulk stored liquids to provide a tank temperature profile and an average temperature.

The MST contains a number of spot elements positioned at different heights in the tank. Only those spots which are fully immersed are used to determine the product temperature.

Rugged construction

The Multiple Spot Thermometer consists of a number of ceramic-platinum elements Pt100 bundled together and housed in a flexible, gas-tight protection tube made of convoluted stainless steel. The protection tubes have rigid stainless steel fittings at the top and bottom.

The top fitting comprises a 305 mm (12 inch) long stainless steel pipe with 250 mm (10 inch) length 1/2-inch BSP thread for fine adjustment of mounting flange position. The top fitting is also filled with epoxy and serves as a gas-tight entry for the color coded electrical connections.

Easy installation

The Multiple Spot Thermometer is easy to install, even while tanks are in service. Generally a 2 inch entry is sufficient. Its sealed construction makes it possible to expose the MST to the tank contents without fear of damage by aggressive substances.

The MST, installed in a closed thermowell, is recommended for use in pressurized tanks since it allows installation and inspection without taking the tank out of service.



APPLICATIONS

- Refined products
- Crude oil
- Bitumen / asphalt
- Chemicals
- LPG/LNG (thermowell version)

Accuracy

The Multiple Spot Thermometer uses 1/6 DIN-elements (1/10 as option). This ensures accurate measurement even under extreme conditions. The number of spots can vary to suit the particular application. The spots are equidistantly positioned to guarantee a precise measurement of the average product temperature. A common distance between the spots is 3 m (10 ft). According to API chapter 7.

Safe

The Multiple Spot Thermometer complies with essential health and safety requirements for installation in hazardous areas.

Specification	
Accuracy 1/6 DIN (std):	±0.05° C (0.09° F) at 0° C (32° F)
Accuracy 1/10 DIN (option):	±0.03° C (0.05° F) at 0° C (32° F)
Outer material:	Stainless steel AISI 316
Overall length:	0.95-70 m (3.1-230 ft)
Sheath diameter:	¾-in. (standard), 1-in. (always with Water Level Sensor)
Top Fitting:	Steel pipe with 1/2-in. BSP thread or M25 x 1.5. Thread length 253 mm (10.0 in.)
No of wires:	3 independent wires per element or 1 wire per element plus 2 common return wires
Element type:	Pt 100 spot elements according to EN 60751
Number of elements:	6 elements per MST as standard. Max. 14 elements for each MST
Overall temp range (standard):	-50 °C to 120 °C (-58 °F to 248 °F)
Overall temp range (optional):	-20 °C to 250 °C (-4 °F to 482 °F) -170 °C to 100 °C (-274 °F to 212 °F)
Lead wire length:	3 m (9.8 ft), other lengths on request

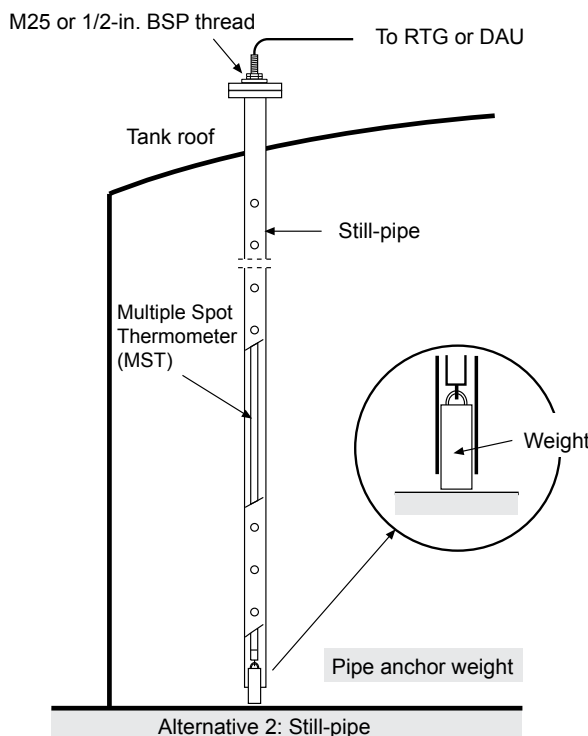
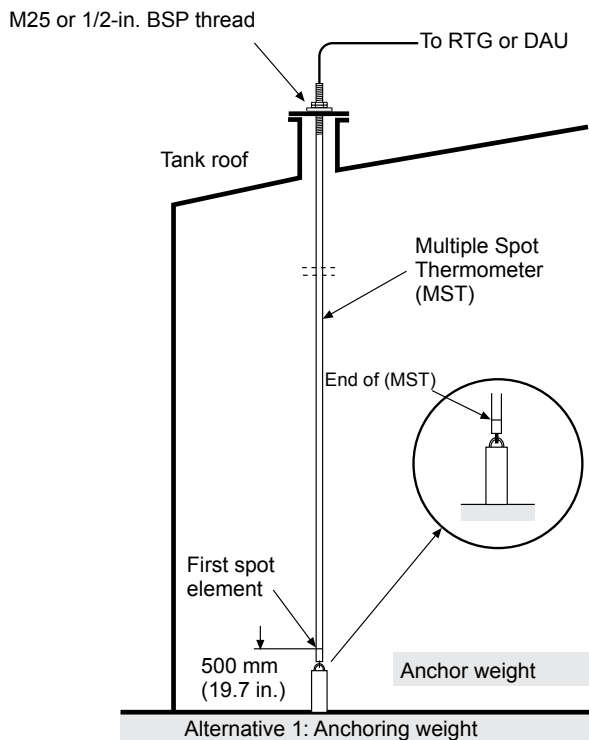

A number of installation alternatives are possible. In alternative 1, the MST is positioned by means of an anchor weight standing on the tank bottom. Alternative 2 shows the MST inside a stilling well with a small weight to stretch the MST, 2,5-4 kg (5.5-8.8 lbs).