

Rosemount TankMaster Inventory Management Software

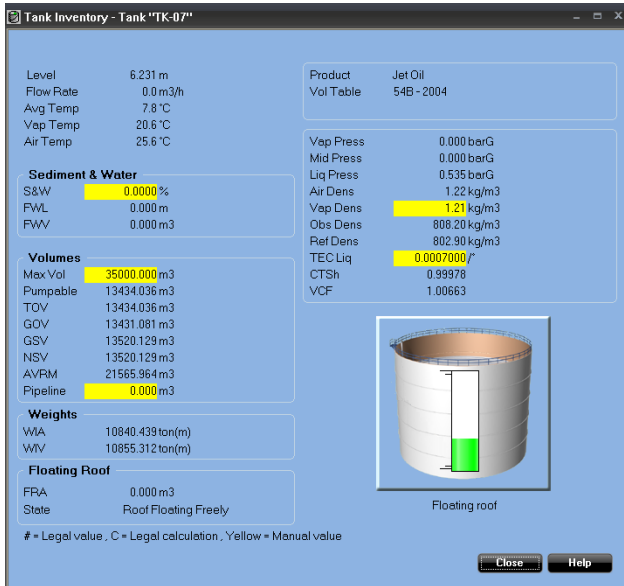

- Increase plant efficiency by getting complete tank overview
- Get real time inventory calculations with API standard net volumes
- Achieve network interoperability with host systems and other vendors
- Improve safety with better alarm management
- Increase reliability with smart redundancy features

Gain control over your inventory data



TankMaster gives the most important inventory data for a specific tank in one easy-to-read window.

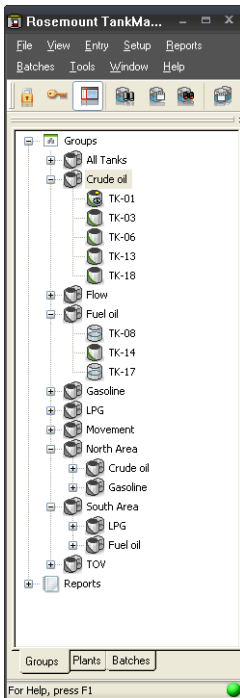

You can easily organize tanks in geographical or product groups, with associated sub-groups.

Just like in "Windows explorer" it is possible to expand and minimize fields and get direct group and tank access by double-clicking the specific group or tank icon.

TankMaster is a powerful, easy-to-use Windows-based inventory management software package. It provides operator overview, inventory and custody transfer functions, configuration and service for Rosemount Tank Gauging systems.

Collecting all tank gauging data such as level, temperature, water interface and pressure from devices in the Rosemount tank gauging system, TankMaster automatically calculates volume and mass for inventory and custody transfer tanks. The operator will be able to respond faster to changing tank farm conditions. This will maximize the plant effectiveness, increase productivity and reduce costs.

Inventory and custody transfer functions

- Real-time tank gauging data such as level, temperature, water interface level and pressure
- Real-time, gross and net volume inventory calculations based on API and ISO standards
- Hybrid tank gauging with pressure inputs giving data for density and mass calculation
- Batch handling makes it possible to control and follow transferred volumes, from the control room

Improve operator overview

The "tank farm explorer" makes it easy to navigate in TankMaster. TankMaster provides several efficient features:

- Customized views with graphic plant layouts
- Advanced group configuration in geographical or product groups etc.
- A user manager with different access levels for personnel
- A setup wizard for guided configuration of all devices in a Rosemount tank gauging system

Contents

Ordering information 4
 Specifications 7

Make essential tank gauging data available

By sharing data with users on all levels of the enterprise through modern network connectivity, operators and plant management are better equipped to make timely decisions.

Full network capabilities

- It is possible to build a network of several server and client PCs with TankMaster software
- The networking function makes it possible to work with TankMaster from any PC in the network
- The operator can install tanks, handle tank gauging and inventory data and accept alarms

TankMaster comes in two versions:

- WinOpi is a complete custody transfer and inventory software package. All calculations are based on current API and ISO standards.
- WinView is a software package with basic inventory capabilities. It is a cost efficient alternative for operational control at smaller tank terminals, marketing terminals, biofuels and chemical plants etc.

There is also a web version available, TankMaster.net. With TankMaster.net it is possible to get an automatic real-time inventory overview of a tank farm via intranet or any PC with internet access.

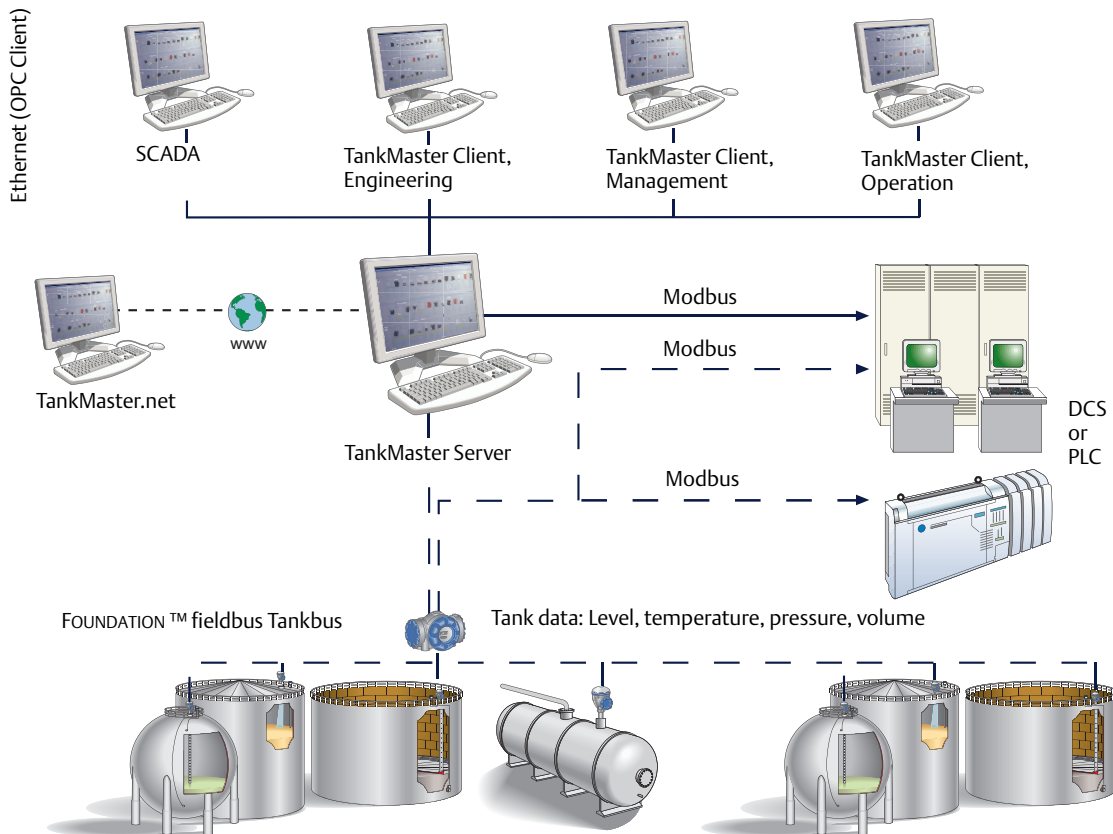

TankMaster distributes essential inventory tank gauging data.

Ordering information

Rosemount TankMaster Inventory Management

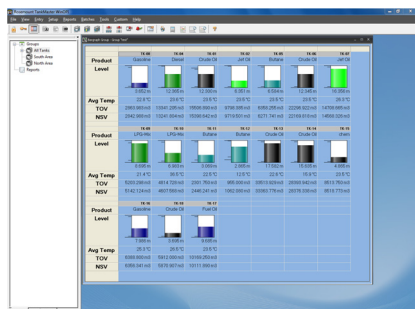

Additional information
Specifications: [page 7](#)

Table 1. Rosemount TankMaster ordering information

Model	Product Description
TM	Rosemount TankMaster Inventory Management
License	
DM	TankMaster Demo (no dongle included)
05 ⁽¹⁾	TankMaster WinOpi, with TankServer for up to 5 tanks, including WinSetup
20 ⁽¹⁾	TankMaster WinOpi, with TankServer for up to 20 tanks, including WinSetup
50 ⁽¹⁾	TankMaster WinOpi, with TankServer for up to 50 tanks, including WinSetup
MX ⁽¹⁾	TankMaster WinOpi Max (unlimited number of tanks), including WinSetup
V2 ⁽²⁾	TankMaster WinView, with TankServer for up to 20 tanks, including WinSetup
V5 ⁽²⁾	TankMaster WinView, with TankServer for up to 50 tanks, including WinSetup
WS ⁽³⁾	TankMaster WinSetup
Host Communication	
0	None
C ⁽⁴⁾	TankMaster communication module
S ^{(4) (5)}	TankMaster communication module with office link
Network	
0	None
1 ⁽⁶⁾	One TankMaster client can connect and read data
2 ⁽⁶⁾	Two TankMaster clients can connect and read data
3 ⁽⁶⁾	Three TankMaster clients can connect and read data
4 ⁽⁶⁾	Four TankMaster clients can connect and read data
5 ⁽⁶⁾	Five TankMaster clients can connect and read data
6 ⁽⁶⁾	Six TankMaster clients can connect and read data
7 ⁽⁶⁾	Seven TankMaster clients can connect and read data
X ⁽⁶⁾	Specify number of clients

Table 1. Rosemount TankMaster ordering information

Custody Transfer	
0	None
C ⁽⁷⁾	TankMaster custody transfer functions
p ⁽⁸⁾	TankMaster custody transfer functions PTB Eich
Batch Handling	
0	Default batch functions
B ⁽⁹⁾	Extended batch functions
HTG	
0	None
P	TankMaster hydrostatic tank gauging functions and calculations
Customization	
0	None
C	Customized views
Redundancy	
00	None
RT ⁽¹⁰⁾	TankMaster redundancy
Typical Model Number: TM 20 S N C C P C RT	

- (1) Configuration, view and alarm handling. Volume calculations according to API.
- (2) Configuration, view, alarm handling and limited inventory calculations. Requires code "0" or "00" for Network, Custody Transfer, Batch Handling, HTG, Customization, and Redundancy.
- (3) Configuration and installation of devices and tanks.
- (4) For connection between TankMaster and SCADA / DCS/PLC via Modbus (RS232) and/or OPC DA. Requires WinOpi.
- (5) For connection between TankMaster and Microsoft Office via OPC server. Includes OPC Office Client / Site Server License.
- (6) Number of other TankMaster PCs that can connect and read data. This other TankMaster PC can be a TankMaster client or another TankMaster server.
- (7) Custody transfer windows. Includes hardware key, custody transfer seal and metrological seal for custody transfer approvals.
- (8) Custody transfer windows. Includes hardware key, PTB sticker, custody transfer seal and metrological seal for custody transfer approvals.
- (9) Stores closed batches up to 365 days, re-calculation of delivery ticket, Microsoft Access database files and "Tank Transfer Calculator".
- (10) Requires two identical dongles (can be ordered separately), meaning duplicate redundancy licenses as well as other options (one per dongle).

Rosemount TankMaster.net

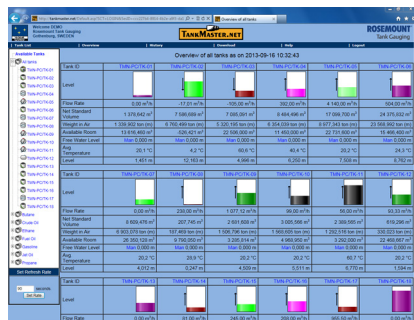

- Supplies an automatic real-time inventory overview of a tankfarm via intranet or any PC with Internet access
- Easily configured with possibility to customize parameters

Additional information

Specifications: [page 7](#)

Table 2. Rosemount TankMaster.net ordering information

Model	Product Description
RTM39EL ⁽¹⁾	Rosemount TankMaster.net, Single License (one user)
RTM39EM ⁽¹⁾	Rosemount TankMaster.net, Limited License (up to 3 users)
RTM39ES ⁽¹⁾	Rosemount TankMaster.net, Site License (unlimited number of users)

(1) Tank data availability through Internet / intranet. Requires TankMaster WinOpi.

Specifications

Functional specifications

For information on what features are included in which TankMaster version, see “TankMaster versions” on page 14.

User-friendly navigation

The “tank farm explorer” makes it easy to navigate in TankMaster. It is possible to expand and minimize fields. The operator gets direct group and tank access by double-clicking the specific group or tank icon.

Customized views

There are a number of options for customized views; it is possible to either modify the existing window, or build completely new ones to show only the currently most interesting tank parameters. For example;

- a photo of the plant gives a realistic view and by clicking a specific tank, the corresponding tank data will be presented
- a window showing only the currently most interesting tank parameters

Interactive configuration and installation

A step-by-step wizard provides guided configuration and installation of all devices in a Rosemount tank gauging system.

Translation

TankMaster can be translated to any language. Users can change text in the dialogs and menus and verify translated text on site.

Tank gauging data

TankMaster collects real-time tank gauging data such as level, temperature, water interface level and pressure.

Hybrid tank gauging

With a high accuracy hybrid tank gauging system the need for manual density sampling is eliminated. With tank gauging data such as level, pressure and temperature the operator gets automatic density measurements and mass calculations from the TankMaster system.

LPG

For tanks containing liquid gas, a number of parameters are relevant. The mass of gas in the Available Room is calculated and the corresponding liquid equivalent volume is presented as Liq Equ in the Tank Inventory window.

The Molecular Mass and the Vapour-Liquid_Volume Ratios are entered into the TankMaster product table.

Density measurement with pressure transmitters

By complementing the level measurement with temperature and pressure measurement, the density of the product in the tank can be continuously calculated.

One or more pressure transmitters with different scalings can be used on the same tank to measure liquid and vapor pressure.

The accuracy of the density calculation largely depends on the accuracy of the pressure transmitter.

Data is calculated according to updated API and ISO standards. Temperature calculations include API algorithms to handle elements close to the bottom. The level value is software corrected for changes in tank reference height.

Data is presented using units from a wide selection, both metric and USA/UK units are supported. Secondary units are available.

TankMaster features very high accuracy net volume calculations (up to 5000 strapping points). Normally less than 100 points per tank are necessary for 1 liter accuracy. Quadratic interpolation for spheres and horizontal cylinders is used, which increases volume accuracy and reduces number of strapping points.

Inventory calculations

Real time inventory calculations include:

- Gross and net volumes as well as mass calculations, according to current API tables (6, 54, 24, A-D), ISO and other major standards
- Tank capacity tables (5000 strapping points) for cylindrical and spherical tanks are supported
- Liquid and mass calculations of vapor in LPG according to ISO 4267
- Net Standard volume calculated at a user specified reference temperature
- Measured and calculated values displayed in secondary units, for example the results can be shown in both bbl and °F, and m³ and °C at the same time

TankMaster calculations

The inventory calculations are normally based on volumes. The main calculation is to find a volume correction factor (VCF). The VCF is then used to calculate volume based on a reference temperature.

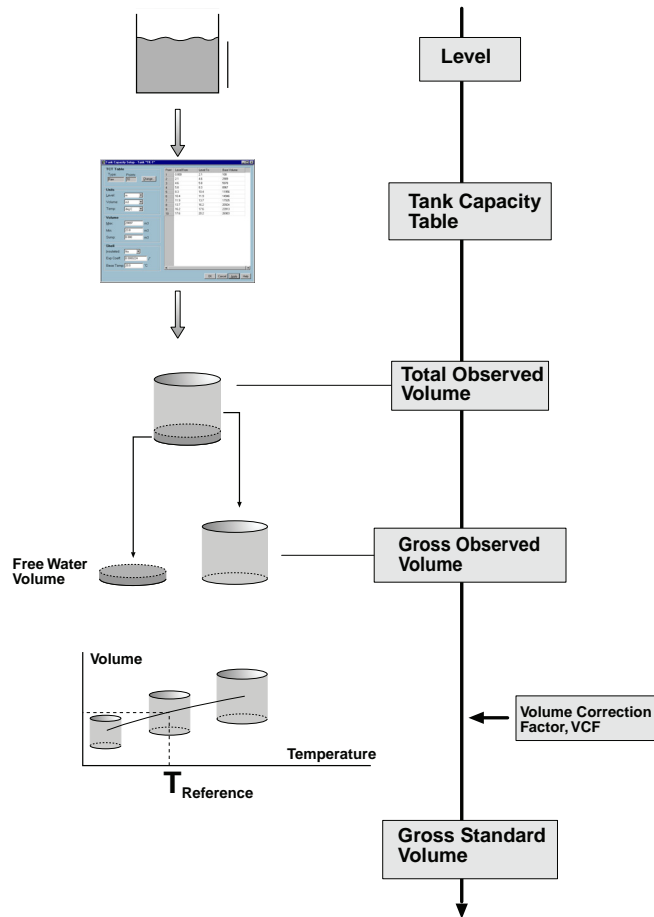

Inventory parameters are calculated based on input data available for the current tank. The figure shows an example of how the measured product level is converted to a standardized volume.

The inventory calculation is divided into four parts:

1. Calculation of observed volumes
2. Calculation of observed density
3. Calculation of reference density and Volume Correction Factor according to the selected volume correction table
4. Net volumes using the VCF

Total Observed Volume (TOV) is calculated from strapping tables. It is the total volume at the observed temperature of the product.

Gross Observed Volume (GOV) is obtained by subtracting the **Free Water Volume (FWV)** from the TOV. The FWV is calculated from the Free Water Level entered by the operator or measured automatically by using a water level sensor, such as Rosemount 765.

Gross Standard Volume (GSV) is the GOV corrected to the reference temperature 15 °C (60 °F). The correction is made using the Volume Correction Factor according to API Standard 2540.

Net Standard Volume (NSV) is calculated as the Gross Standard Volume minus the dissolved sediment and water. For liquid gas tanks, the liquid equivalent volume of the gas above the product surface is added. The WinOpi also includes a Leak Alarm based on changes of the NSV.

If a pressure transducer is installed in the tank and properly connected and configured, the density of the product can be calculated. This value is presented as the **Observed Density**.

The **Reference Density** is the density of the product at the standard reference temperature 15 °C (60 °F). It can either be manually entered, or automatically calculated from the Average Temperature and the Observed Density if it is available. The Reference Density is calculated using a VCF according to API Tables 5A, 5B, 53A, or 53B. The Observed Density can also be calculated based on the manually entered Reference Density.

Weight calculations are performed using the calculated volumes and either the manually entered density or the observed density. **The Weight In Air (WIA)** is calculated as the Net Standard Volume multiplied by the Weight Conversion Factor.

Figure 1. Tank parameters and physical quantities

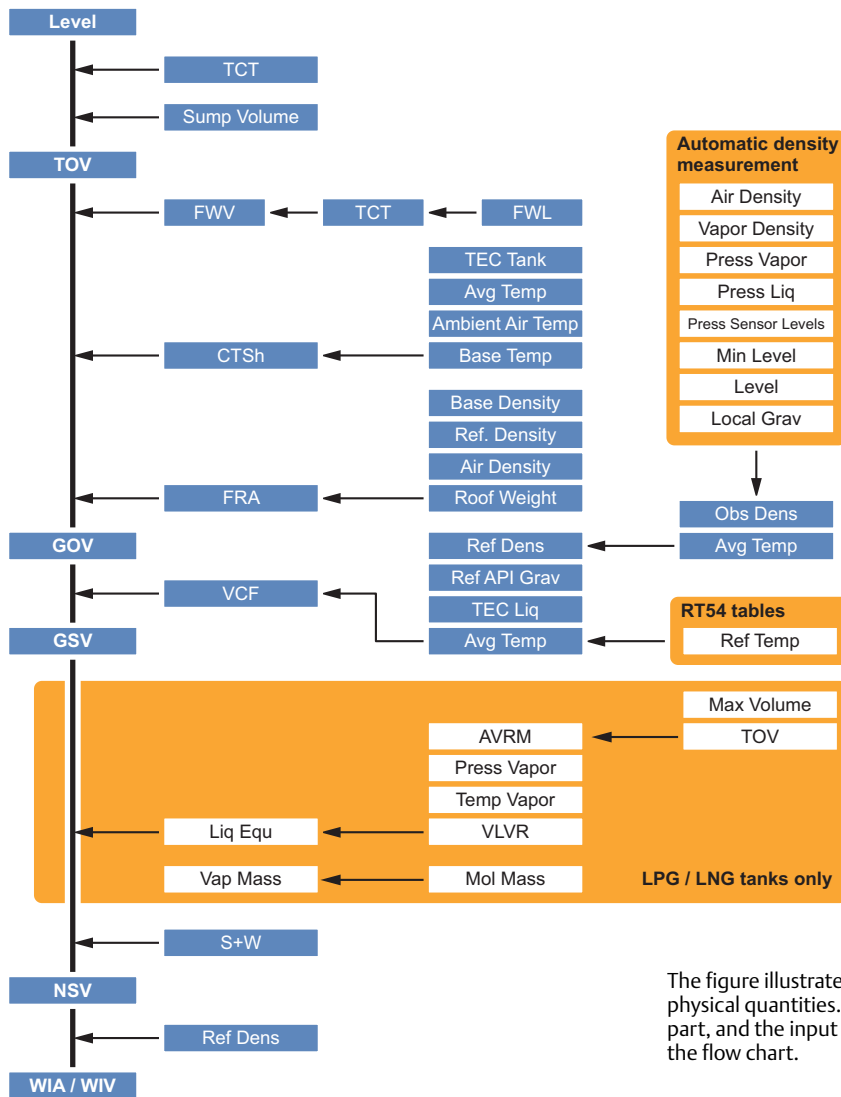

The figure illustrates the relationship between tank parameters and physical quantities. The main parameters are shown in the left-hand part, and the input parameters are shown in the right-hand part of the flow chart.

TOV	Total Observed Volume	CTSh	Correction for tank shell temperature
GOV	Gross Observed Volume	TEC	Tank shell Expansion Coefficient
GSV	Gross Standard Volume	FRA	Floating Roof Adjustment
NSV	Net Standard Volume	VCF	Volume Correction Factor
WIA / WIV	Weight In Air / Weight In Vacuum	S+W	Sediment and Water
TCT	Tank Capacity Table	AVRM	Available Room
FWL / FWV	Free Water Level / Free Water Volume	VLVR	Vapor Liquid Volume Ratio

Batch reports

The batch report provides transfer supervision, when making internal and external transfers in inventory and custody transfer tanks.

When e.g. a ship calls at a plant, a batch report can be started which presents information about when the transfer was started, elapsed time, remaining time and estimated stop. An alarm is activated 5 minutes before, as well as after the transfer is ready. When the transfer is ready, the batch report can be printed for record keeping.

Automatic reports

Standard reports are automatically generated via PDF, text file, printer or e-mail. The reports are arranged by tanks or groups. The time interval, report layout and which parameters to include can be specified by the operator. All activities have a time stamp for reliable follow up.

Two standard report types are available: Log Report and Mass Balance Report.

The Log Report shows:

- product
- level
- average temperature
- Net Standard Volume (NSV)
- density
- level status

LogReport							
Date: 2006-02-22 10:08:30							
Tanks: All Tanks							ReportNr: 1
Tank	Product	Level	Avg Temp	NSV	Ref. Density	Status	
TK-1	Crude Oil	18.809 m	22.0 °C	46626.245 m ³	1000.0 kg/m ³	HiHi	
TK-2	Fuel Oil	18.103 m	22.1 °C	14332.319 m ³	1000.0 kg/m ³		
TK-3	Jet Oil	15.541 m	22.1 °C	7459.873 m ³	1000.0 kg/m ³		

The Mass Balance Report shows:

- product
- level
- average temperature
- Total Observed Volume (TOV)
- Net Standard Volume (NSV)
- Weight In Air (WIA)
- density
- level status
- difference in Net Standard Volume since last report

MassBalanceReport							
Date: 2006-02-21 13:01:04							
Tanks: All Tanks							
Name	Prod Desc	Level	Avg Temp	TOV	NSV	DensRef	
TK-1	Crude Oil	18.809 m	22.0 °C	46626.467 m ³	46626.245 m ³	1000.0 kg/m ³	46
TK-2	Fuel Oil	18.103 m	22.1 °C	14419.969 m ³	14332.319 m ³	1000.0 kg/m ³	14
TK-3	Jet Oil	15.541 m	22.1 °C	7502.310 m ³	7459.873 m ³	1000.0 kg/m ³	7

Alarm handling

TankMaster features alarm summary, alarm log and alarm event log for safe and reliable alarm handling.

When an alarm occurs, a bell rings and the alarm icon starts to blink. The operator can set different sounds for each alarm type. Alarms can also be sent via e-mail, or to mobile phones via an SMS Gateway. Alarms are customized at any station in the network and a client signature is saved at every acknowledgment. It is possible to view all alarms in the system or divide the alarms per group or per tank.

The operator can set alarm levels as well as hysteresis and delay times for level, average temperature, vapor temperature, analog input signals, flow rate, flow direction, and others.

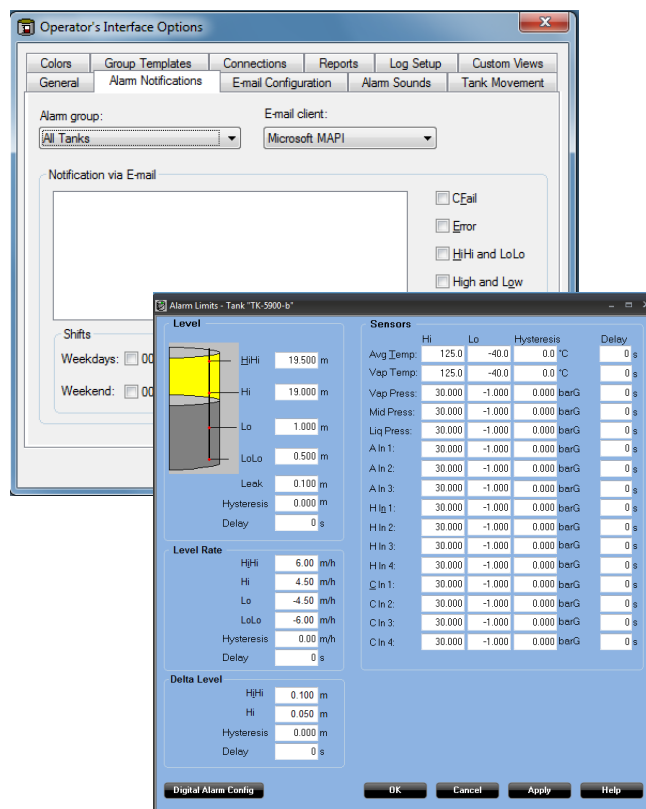

The status of the alarms can be either HiHi, High, Low, LoLo, Error, Leak Hi, Leak Lo, CFail (communication failure), or Normal.

Historical data sampling

The operator can collect historical data for reliable follow up. The generated reports are saved to file. A graph presents the historical trends.

Network capabilities

A network of several server and client PCs can be built. Access TankMaster from any PC in the network.

The networking functions enables working with TankMaster from any PC in the network. Updated real-time data are available on all TankMaster client PC:s. The operator can install tanks, handle tank gauging and inventory data and accept alarms on any PC.

Authority for alarm handling can be distributed in the network. If there are many control rooms the operator can decide who will be responsible for which tanks in the tank farm, giving high security.

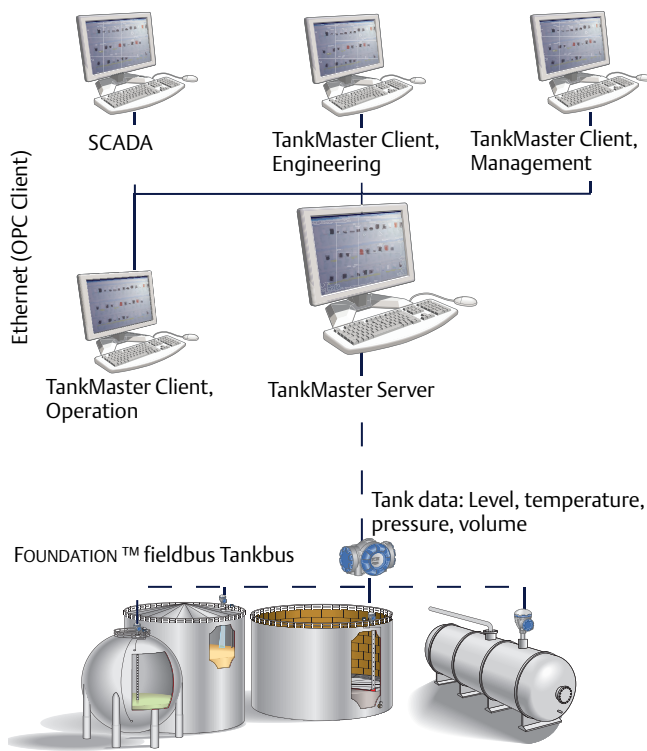

Security

User manager

Several protection levels are implemented to avoid unauthorized changes. These protection levels are categorized as User Access Levels and User Sub Access Levels.

The User Access Levels are:

- Administrator
- Supervisor
- Operator
- View Only

Each User Access Level has five User Sub Access Levels. This gives a total of 20 unique access levels.

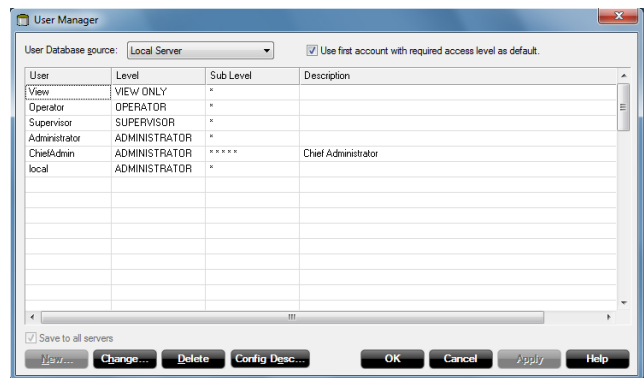

The users can log on and off without restarting the program. In the alarm log it is possible to track who acknowledged a certain alarm. When the shift is over the operator logs out and the new operator takes over and logs in.

In order to change tank and device configuration, to install new tanks and devices, to calibrate a transmitter, to change holding register values etc. the user has to be logged on to TankMaster. To perform any such action the user has to be logged on at the required access level for that action. Different access levels can be set for each window.

Backup

The backup function can be used to save configuration data for devices and tanks as well as workspace settings.

This function preserves all settings in a format which facilitates a full system restore. Using the backup functionality, the following data can be stored:

- tank and device configurations
- any previously created Historical Data
- workspace configuration such as tank groups, colors, network settings etc.

Supported devices

The WinSetup program supports installation and configuration of the following device types:

Table 3.

Supported device types
5900S Radar Level Gauge
5300 Guided Wave Radar Level
5400 Radar Level Transmitter
2410 Tank Hub
2240S Multi-input Temperature Transmitter
2230 Graphical Field Display
RTG 3900 (TankRadar Rex)
RTG (TankRadar Pro)
RTG 2900 (TRL2)
2160 Field Communication Unit
2165 Field Communication Unit
Independent Data Acquisition Unit (IDAU)
Slave Data Acquisition Unit (SDAU)
IOT 5110
IOT 5120
IOT 5130
IOT 5140
TRL PU
ILS 2000
Enraf CIU
Endress & Hauser MDP2
L&J MCG 3221
DS4
Generic ModbusMaster Device (small size)
Generic ModbusMaster Device (large size)
Generic OPC Server Device (small size)
Generic OPC Server Device (large size)

Open system solution enables integration of other vendor’s systems

OPC server with browser

TankMaster uses OPC Data Access 2.0 (OLE for Process Control), an open industry standard, which eliminates the need for costly customized software integration.

With the OPC server and the browser it is possible to import all custody transfer and inventory data to other OPC clients such as different DCS:s, PLC:s, Scada systems, or Microsoft Office programs.

(Website OPC Foundation: www.opcfoundation.org)

Connection to other systems

The Rosemount tank gauging system can be connected to all major suppliers of DCS, SCADA systems, plant host computers or terminal automation systems. The connection can be made in two ways:

- To a TankMaster PC workstation
- Directly to a Rosemount 2160 unit

The advantage of connecting to a TankMaster workstation is that not only the measured values, but also the values calculated by the TankMaster can be communicated.

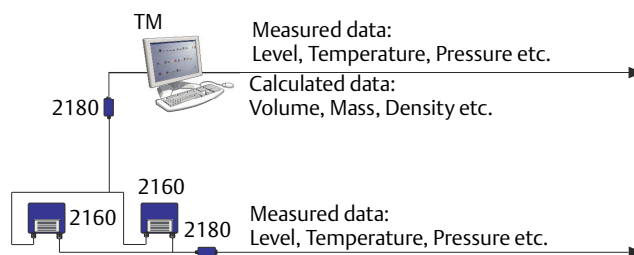

The host computer can be connected either to a TankMaster (TM) PC or directly to the 2160.

Emulation

It is possible to seamlessly replace other tank management systems with Rosemount TankMaster. Data from different types of units is collected and displayed.

Redundancy

In order to reduce the risk of communication failure between the TankMaster/DCS system and the units connected to the Tankbus, redundancy can be made in several ways.

Redundant TankMaster PC:s

A system can have two redundant TankMaster PC:s connected via two different group buses to one or several Rosemount 2160 units.

There are two possible TankMaster configurations:

- Both PC:s active, and separately asking for data
- One primary active PC, and the other silent in backup mode (hot standby)

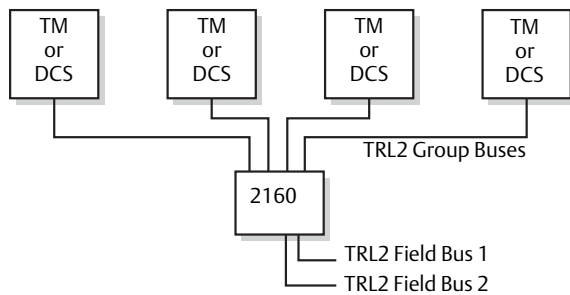

There can be up to four connections to TankMaster (TM) or DCS units on the group bus ports of the 2160.

Redundant 2160 Field Communication Units

With two 2160:s connected in parallel to the field buses, one of the 2160:s will be configured as the primary unit and will be in an active state. The other unit will be in a back-up state.

A control signal is sent between the two units. If the backup unit is not receiving this signal, or if the primary unit has a problem, then the backup unit takes over the active role.

A message is sent to TankMaster (or DCS) that the primary unit has failed and that the backup unit has taken over the communication.

Complete control room redundancy

Complete field to control room redundancy is achieved by using redundant 2160 Field Communication Units, 2180 Fieldbus Modems and TankMaster PC:s.

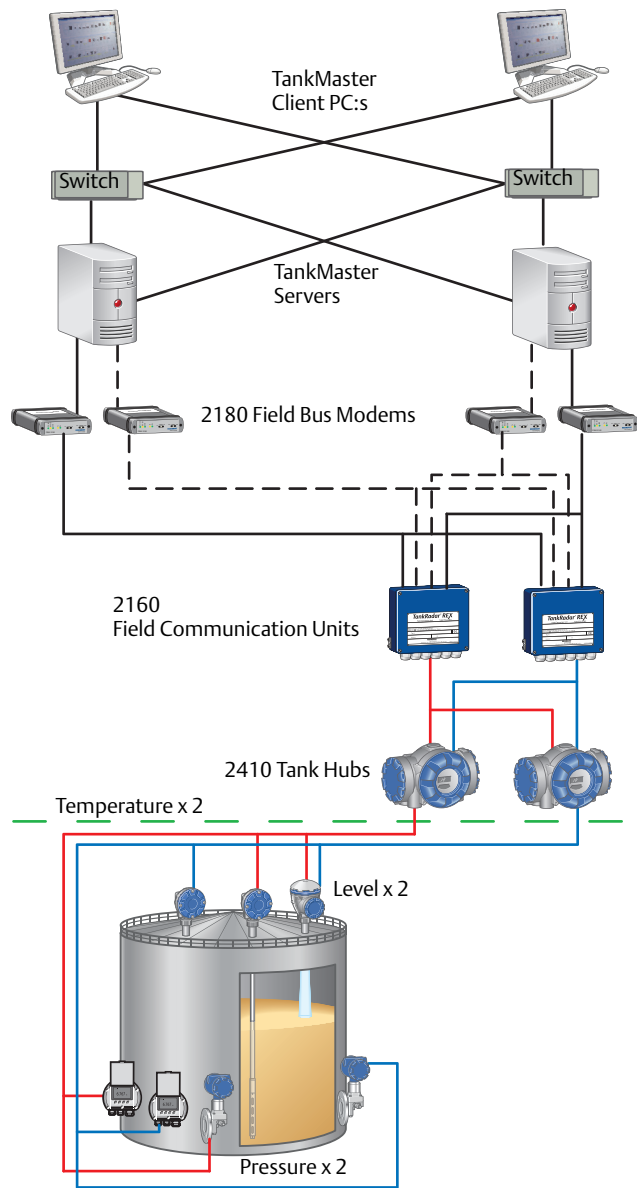

Tankbus and field network redundancy

It is possible to have two Rosemount 2410 Tank Hubs with two separate Tankbuses on the same tank.

All field devices can also be configured in pair:

- Double level measurement devices (two separate gauges or a 2-in-1 gauge)
- Double temperature transmitters with associated sensors
- Double liquid pressure transmitters

TankMaster versions

- **WinOpi** is a complete custody transfer and inventory software package. All calculations are based on current API and ISO standards. Configuration of the Rosemount Tank Gauging system is made with **WinSetup**, which is included in the delivery.
- **WinView** is a software package with basic inventory capabilities. It is a cost efficient alternative for operational control at smaller tank terminals, marketing terminals, biofuels and chemical plants, etc. Configuration is made with **WinSetup**, which is included in the delivery.

See [Table 5](#), for further information.

TankMaster.net the TankMaster web version

There is also a web version available, TankMaster.net. It monitors the tank farm inventory data on a secure web site. From there, real-time information is available for customers, suppliers, corporate management, and others via the Internet or the corporate intranet.

Tank content levels, volumes and temperatures are viewed in all standard browsers, as are transactions and other historical events. Values, trends, utilization etc can be observed.

All users get unique usernames and passwords, giving access only to their dedicated tanks.

Table 4. TankMaster.net features

Feature
Includes virtually all monitoring functions from TankMaster
Fulfills industry and legal requirements such as API etc.
Open system architecture based on OPC/OLE industry standard
Inventory control available 24 hours a day, at any location
Shared information: suppliers, customers and transporters get automatic real-time inventory overview via Internet or intranet
User-friendly navigation
Interactive configuration and installation

Table 5. Comparison between WinOpi and WinView

Feature	WinOpi	WinView
Alarms	Yes	Yes
Host communication, Modbus and OPC	Yes	Yes
Custody transfer	Yes	No
API tables	Yes	No
Batch handling	Yes	No
Reports	Yes	Yes, partly
Translation	Yes	Yes
TankMaster network support	Yes	No
TankMaster.net	Yes	No
Customization	Yes	No
Create new group of tanks	Yes	No ⁽¹⁾
Redundancy	Yes	No
HTG (hybrid tank gauging)	Yes	No
Supported (measured or calculated) data parameters	WinOpi	WinView
Level	Yes	Yes
Ullage	Yes	No
Level rate	Yes	Yes
Flow rate	Yes	Yes
Average temperature	Yes	Yes
Spot temperature	Yes	Yes
Vapor temperature	Yes	No
Air temperature	Yes	No
Free water level	Yes	Yes
Free water volume	Yes	Yes
Total observed volume (TOV)	Yes	Yes
Gross observed volume (GOV)	Yes	No
Gross standard volume (GSV)	Yes	No
Net standard volume (NSV)	Yes	No
Vapor, liquid, and air pressure	Yes	No
Observed density	Yes	Yes, manually entered
Reference density	Yes	No
Mass calculations	Yes	Yes, limited

(1) Possibility to edit existing group ("All tanks").

Tank inventory calculator

A tool that calculates inventory values based on operator entered input values and the selected tank configuration. Input value fields are initiated with the current tank configuration and input values from devices. The operator can then change some or all input values and press the “Calculate” button to calculate inventory values.

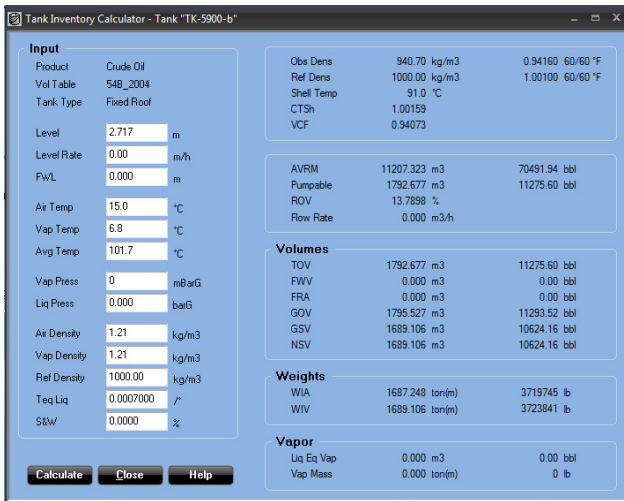

Tank transfer calculator

A tool for the operator to calculate transferred product values or closing values using inventory parameters.



System requirements

TankMaster WinOpi, WinSetup and WinView

Operating system

English version of:

- Windows 7 Professional, 32- and 64-bit versions, with service pack 1 (SP 1)
- Windows 2008 Server Standard, 32- and 64-bit version with service pack 2 (SP 2)
- Windows 2008 Server R2, 64-bit versions with service pack 1 (SP 1)

TankMaster PC hardware

Processor

2.5 GHz, multi-core processor

RAM memory

4 GB

Disk drive

40 GB (TankMaster combined with SQL Server 2005 Express, needs approximately 600 MB)

Serial port

RS232, or USB if FBM 2180 is used. For more information about Rosemount 2180 Field Bus Modem, see the Rosemount Tank Gauging Accessories Product Data Sheet (00813-0100-5101).

Hardware key

The TankMaster server needs one USB port for the hardware key

Rosemount TankMaster.net

Operating system

English version of:

- Windows XP Professional, 32-bit version with service pack 3 (SP 3)
- Windows Vista Business, 32-bit version with service pack 2 (SP 2)
- Windows 7 Professional, 32-bit version with service pack 1 (SP 1)
- Windows Server 2008 Standard, 32-bit version with service pack 2 (SP 2)

Installation of Internet Information Services (IIS) is recommended for TankMaster.net servers

Server PC hardware

Processor

1.8 GHz (single processor) or better

RAM memory

256 MB (1024 MB recommended)

Disk drive

20 GB

Bandwidth to each TankMaster PC

20 kbps for each connected tank

Internet bandwidth

64 kbps (256 kbps recommended)

Client PC hardware

Processor

1.3 GHz (single processor) or better

RAM memory

256 MB (1024 MB recommended)

Disk drive

20 GB

Network connection

LAN or Internet

Internet bandwidth

64 kbps (256 kbps recommended)

TankMaster.net client Palm or phone hardware

Network connection

WAP 2.0, Internet connectivity

**Emerson Process Management
Rosemount Tank Gauging**

Box 130 45
SE-402 51 Göteborg
SWEDEN
Tel: +46 31 337 00 00
Fax: +46 31 25 30 22
E-mail: sales.rtg@emerson.com
www.rosemount-tg.com

**Emerson Process Management
Rosemount Tank Gauging North America Inc.**

6005 Rogerdale Road
Mail Stop NC 136
77072 TX Houston
United States
Primary Phone: +1 281 988 4000
Secondary Phone: +1 800 722 2865
E-mail: sales.rtg.hou@emerson.com

**Emerson Process Management
Latin America**

1300 Concord Terrace, Suite 400
Sunrise Florida 33323
United States
Tel: +1 954 846 5030

**Emerson Process Management
Rosemount Tank Gauging Middle East & Africa.**

P. O Box 20048
Manama
Bahrain
Tel: +973 1722 6610
Fax: +973 1722 7771
E-mail: rtgmea.sales@emerson.com

**Emerson Process Management
Asia Pacific Pte Ltd**

1 Pandan Crescent
SINGAPORE 128461
Tel: +65 6777 8211
Fax: +65 6777 0947
Email: specialist-itg.rmt-ap@ap.emersonprocess.com

The Emerson logo is a trade mark and service mark of Emerson Electric Co.
Rosemount and the Rosemount logotype are registered trademarks of Rosemount Inc.
PlantWeb is a registered trademark of one of the Emerson Process Management group of companies.
HART and WirelessHART are registered trademarks of the HART Communication Foundation
All other marks are the property of their respective owners.
© 2014 Rosemount Tank Radar AB. All rights reserved.

