

PRODUCT SPECIFICATIONS

# Thermo Scientific Sarasota FD900, ID900, PD900

## Gas Density Meters

The advanced Thermo Scientific™ gas density meters are engineered to reliably measure density or density related variables within the oil and gas, petrochemical and power industries. Offering near real-time control signal availability and a low cost of ownership compared to chromatographs and other alternative measurement methods, the meters ensure plant efficiency and vitality.

### Features

- Continuous, online density monitoring
- Measurement at true process conditions
- Insertion, sample by-pass and pocket options
- Compact design
- Hazardous area approvals
- Converter electronics to suit application

### Applications

- Fiscal/custody transfer gas metering
- Fuel gas analysis
- Burner control
- Ethane cracking and ethylene production
- Energy management systems
- Stack emissions analysis and control
- LNG metering and control
- Calorific value estimation
- Specific gravity measurement
- Process/quality control
- Product identification
- Blending/peak shaving

### Real-time control

Process optimization and product quality control are achieved through the close control of process parameters and final product quality. The composition of any gas is often characterized by its density or specific gravity. Thermo Scientific gas



density meters provide continuous, inline monitoring of the density, or density related variables, to instantly detect any variation of process constituents or final product quality. The results are improved productivity, minimized product waste and reduced costs by providing real-time control as opposed to sampling methods.

### Compatible outputs

Output variables, such as specific gravity, calorific value or molecular weight, can be provided either by a third party flowmeter or by a Thermo Scientific™ Density Converter. The Thermo Scientific™ Sarasota HME900 field-mounted density

converter option provides a direct HART® compatible output, whereas the Thermo Scientific CM515 panel-mounted electronics unit provides the most accurate conversion to maintain optimal process conditions.

### General features of the range

The reliability and high accuracy required for fiscal applications are achieved using the Thermo Scientific proven technology of a vibrating cylinder (spool) design, with several additional design features, to ensure the high integrity of the measurement. An integral, high grade PT100 resistance temperature device mounted within the instrument gives a live temperature reading at process conditions to ensure precise compensation of the density coefficients and the ability to compensate the process fluid to reference or other conditions.



The effects of any dirt in the process fluid are minimized by the probe sampling method and the use of instrument filters, according to the model. Pressure effects are eliminated on all models because the sensor remains completely surrounded by the process fluid. Different sensor material options and BS EN ISO 15156/ NACE MR0175 conformance treatment are available to meet the extreme demands of corrosive, cryogenic, high temperature or high pressure applications.

Offering hazardous area approvals, Thermo Scientific gas density meters are suitable for use in even the most hostile of environments.

### Density converter electronics

A choice of density converter solutions offers end users full flexibility in the processing of the measurement data to best suit the application.

A field-mounted Sarasota HME900 head mounted electronics unit conditions the output signal to give a HART compatible 4-20 mA output that can then be interrogated by any HART system. A local display on the Sarasota HME900 allows the process engineer to view the prime variable value either in engineering units alone or with an alternating display of percent of chosen span.

Alternatively, the frequency and PRT (RTD) outputs from the density meter may be taken to a third party flow computer or remote Thermo Scientific CM515 density converter, a versatile unit that can be configured as required, depending on the input/output requirements of the end user's application. This unit performs calculations to give the required density or density derived parameter to ensure data integrity and enable instrument optimization.

### Applications expertise

We have over 30 years of applications expertise in the density measurement of gases and liquefied gases, particularly in the oil and gas, petrochemical and power industries. To accommodate the needs of the industries' differing configuration requirements, the Thermo Scientific range of gas density meters includes the Sarasota ID900 direct insertion, Sarasota FD900 by-pass, and Sarasota PD900 pocket models.

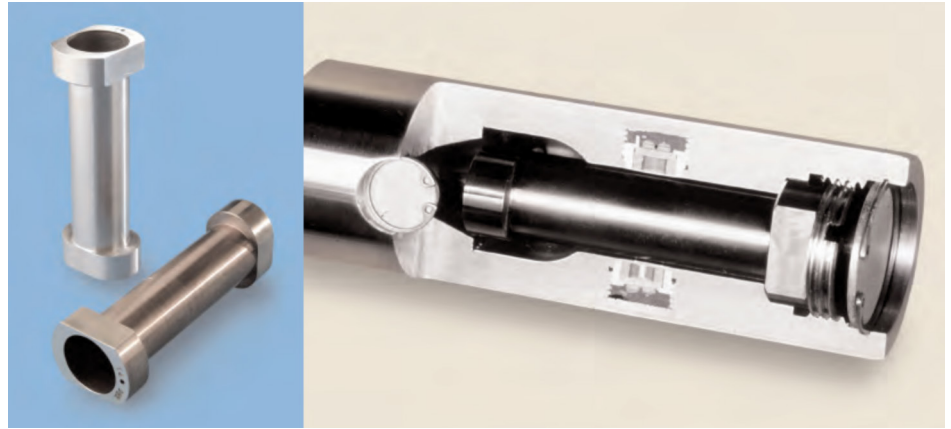

The optimum choice of a Thermo Scientific density meter is determined by factors including the pipeline or sample line size; the line pressure and flow rate; the process fluid temperature and type; the accuracy required; the maintenance requirements; whether it is a new or retrofit installation; and hazardous area requirements.

### Thermo Scientific Sarasota ID900 for direct Insertion applications

The Sarasota ID900 insertion density meter is installed directly into the pipeline or vessel, using its integral flanges or the Thermo Scientific Sarasota RTR900 instrument retractor. The Sarasota RTR900 allows the meter to be removed from a pressurized line without having to shut down the line or process, avoiding downtime.

With its uniquely designed measuring chamber, the effects of any dirt in the process fluid are minimized. The use of insertion techniques ensures that process fluid, density and temperature measurements are at true process conditions. This, together with the absence of pressure or temperature differentials associated with sample or by-pass lines, ensures that the high accuracy and repeatability required for fiscal applications or fuel management systems are achievable at a relatively low installed cost.

### Thermo Scientific Sarasota PD900 for pocket applications

The Sarasota PD900 pocket density meter offers many of the same design features as the Sarasota ID900 but is mounted into a thermowell pocket that is installed directly into the pipeline. Since the pocket

is in the pipeline, density and temperature measurements are at near process conditions and the use of an inlet filter prevents dirt or moisture from entering the measuring chamber. The process fluid passes through the measuring chamber from a sample line and is subsequently returned to the sample line. Removal and servicing of the meter does not require pipeline shutdown.

The meter can be installed on a retrofit basis into the pockets of other manufacturers' pocket density meters, giving end users the benefit of optimum density measurement as well as high temperature and NACE treatment options with minimal installation costs.

### Thermo Scientific Sarasota FD900 for by-pass applications

The Sarasota FD900 is normally installed on a by-pass sample line. Where the line size is 25 mm (1 in) or less, it may be placed directly inline. A choice of fittings and flange options is available to suit the pipe work configuration. Density and temperature measurements are therefore at line or near line conditions.

In applications where the gas is particularly dirty or wet and requires filtering prior to the measurement, and where SG or molecular weight (MW) can be used to infer density elsewhere in the plant, the Thermo Scientific Sarasota SG901 specific gravity analyzer is recommended. The Sarasota SG901 system incorporates a Thermo Scientific Sarasota FD900 density meter, pressure transmitter, filters, flowmeters, flow regulators, drains and safety relief vents to suit the application.

The Sarasota FD900 and Sarasota SG901 systems have a key role in energy determination, blending control, standard volume flow calculation and fuel gas monitoring.

### Calibration and service

The calibration of the gas density meters is undertaken in-house on a calibration rig that is

traceable to national standards. Supporting documentation is available including a traceable equipment list.

For most applications, installation is straightforward, on-site calibration is generally unnecessary and the instruments are usually maintenance-free. However,

installation, commissioning, maintenance and repair service for the gas density meter range and associated electronics is available. On-site visits, in-house repairs and maintenance contracts can be arranged as required to ensure maximum uptime.

### Sarasota FD900 dimensional diagram

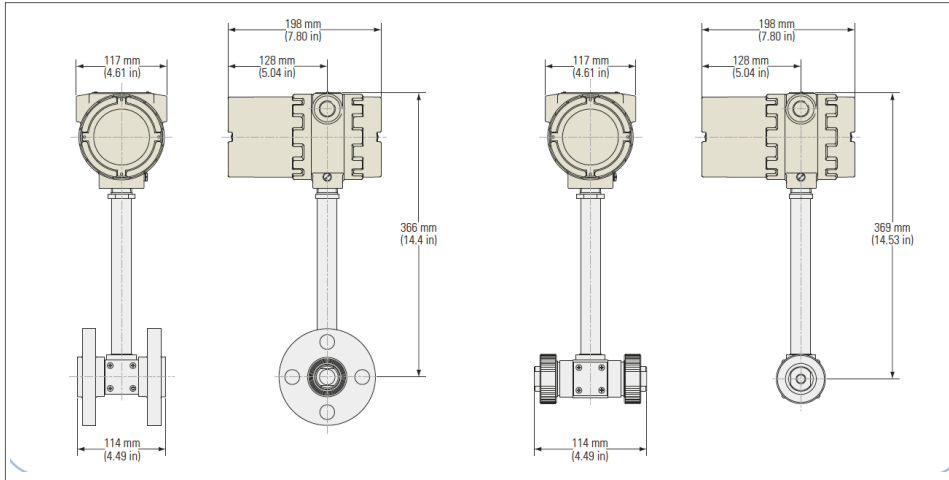

### Sarasota ID900 dimensional diagram

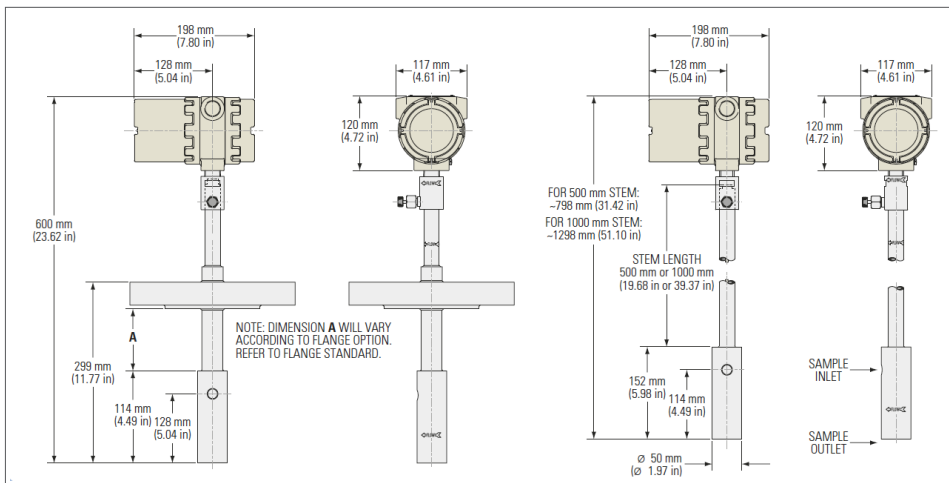

### Sarasota PD900 dimensional diagram

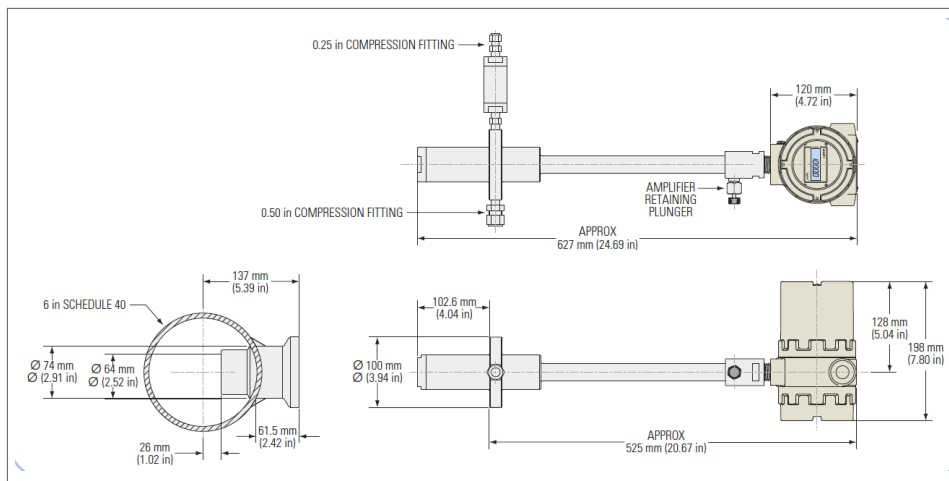

## Ordering information

### Sarasota SC901 Gravity Analyzer

#### MODEL NUMBER

ID900F = Sarasota ID900 Insertion Gas Density Meter—Frequency Output (no local display)

ID900H = Sarasota ID900 Insertion Gas Density Meter with Smart Headmounted Electronics and Local Display

FD900F = Sarasota FD900 By-pass Gas Density Meter—Frequency Output (no local display)

FD900H = Sarasota FD900 By-pass Gas Density Meter with Smart Headmounted Electronics and Local Display

PD900F = Sarasota PD900 Pocket Gas Density Meter—Frequency Output (no local display)

PD900H = Sarasota PD900 Pocket Gas Density Meter with Smart Headmounted Electronics and Local Display

#### A. DENSITY RANGE

A = 0 kg/m<sup>3</sup> to 20 kg/m<sup>3</sup> (0 lb/ft<sup>3</sup> to 1.2 lb/ft<sup>3</sup>)

B = 15kg/m<sup>3</sup> to 80 kg/m<sup>3</sup> (0.9 lb/ft<sup>3</sup> to 5 lb/ft<sup>3</sup>)

C = 75kg/m<sup>3</sup> to 250 kg/m<sup>3</sup> (4.6 lb/ft<sup>3</sup> to 15.6 lb/ft<sup>3</sup>)

D = 200 kg/m<sup>3</sup> to 500 kg/m<sup>3</sup> (12.5 lb/ft<sup>3</sup> to 31.2 lb/ft<sup>3</sup>) (Note: Sarasota ID900 and Sarasota FD900 only)

E = 500 kg/m<sup>3</sup> to 1000 kg/m<sup>3</sup> (31.2 lb/ft<sup>3</sup> to 62.4 lb/ft<sup>3</sup>) (Note: Sarasota ID900 and Sarasota FD900 only)

#### B. TEMPERATURE RANGE

A = -200°C to + 75°C (-328°F to + 167°F)

B = -20°C to + 75°C (-4°F to + 167°F)

C = -20°C to + 200°C (-4°F to + 392°F) (FV520B spool only)

#### C. SPOOL MATERIAL

Z = Ni-Span C®

Y = FV520B

#### D. INSTALLATION CONFIGURATION OPTIONS — PART 1

##### SARASOTA ID900 CONNECTIONS

C = Via flange and 1-in compression fitting (flange and compression fitting not supplied)

D = Via Sarasota RTR900 (requires 1000 mm (39.4 in) stem)

F0 = Integral flange 3-in ANSI 300 lb

F1 = Integral flange 3-in ANSI 150 lb

F2 = Integral flange 3-in ANSI 600 lb

F6 = Integral flange 3-in ANSI 900 lb

##### SARASOTA FD900 CONNECTIONS

A = 1-in ANSI 600 lb

C = 1.5-in BSP screwed body with adapters

##### SARASOTA PD900 SAMPLE FILTER OPTIONS

E = Standard inlet dry particulate filter

#### E. INSTALLATION CONFIGURATION OPTIONS — PART 2 (ID900 only)

##### SARASOTA ID900 STEM LENGTH

SF = 300 mm (11.8") for integral flanged option

L = 1000 mm (39.4") for Sarasota RTR900 option

#### E. CERTIFICATION — FD900 and PD900

C = CSA explosion-proof Class I Div 1, Groups B, C & D

I = ATEX intrinsically safe (Note: for hazardous areas, consult Thermo Fisher Scientific)

#### F. CERTIFICATION—ID900

C = CSA explosion-proof Class I Div 1, Groups B, C & D

I = ATEX intrinsically safe (Note: for hazardous areas, consult Thermo Fisher)

#### F. OPTIONS—FD900 and PD900 only

M = Wetted parts traceability certification to BS EN 10204.3.1.b

N = BS EN ISO 15156/NACE MR0175 conformance certification

T = Traceable calibration equipment listing

D = Non-destructive testing (Note: PD900 only)

#### G. OPTIONS / ID900 only

M = Wetted parts traceability certification to BS EN 10204.3.1.b

N = BS EN ISO 15156/NACE MR0175 conformance certification

T = Traceable calibration equipment listing

D = Non-destructive testing

#### Your Order Code: RTR900 –

--	--	--	--	--

NOTE: Consult Thermo Fisher for details of maintenance contracts and additional services including installation, commissioning, re-calibration, service or repair.

## Thermo Scientific™ Sarasota FD-ID-PD900 Density Meter

Functional specifications	
Transducer calibration accuracy	2 kg/m <sup>3</sup> (0.125 lb/ft <sup>3</sup> ) and above: ±0.1% reading; below 2 kg/m <sup>3</sup> (0.125 lb/ft <sup>3</sup> ): ±0.002 kg/m <sup>3</sup> (±0.000125 lb/ft <sup>3</sup> )
Repeatability	±0.01% span
Flow range	Sarasota FD900/Sarasota PD900: Ideally 4 l/min to 20 l/min (0.14 ft <sup>3</sup> /min to 0.71 ft <sup>3</sup> /min) Sarasota ID900: Normal pipeline velocities. Accuracy unaffected by velocity
Temperature effect (corrected)	Sarasota FD900/Sarasota ID900: 0 kg/m <sup>3</sup> to 1000 kg/m <sup>3</sup> (0 lb/ft <sup>3</sup> to 62.4 lb/ft <sup>3</sup> ) Sarasota PD900: 0 kg/m <sup>3</sup> to 250 kg/m <sup>3</sup> (0 lb/ft <sup>3</sup> to 15.6 lb/ft <sup>3</sup> )
Temperature coefficient (corrected)	0.001 kg/m <sup>3</sup> /°C (0.000035 lb/ft <sup>3</sup> /°F) note: correction coefficients applied (brackets with NiSpan C sensor)
Installation	Ideally within 15° of vertical, for other orientations consult Thermo Fisher
Density meter dimensions	See dimensional diagrams
Shipping dimensions	Sarasota FD900: 610 mm × 360 mm × 360 mm (approx 24 in × 14 in × 14 in); Sarasota ID900/fixed flange: 610 mm × 360 mm × 360 mm (approx 24 in × 14 in × 14 in); Sarasota ID900/1 m stem: 1320 mm × 230 mm × 230 mm (approx 52 in × 9 in × 9 in); Sarasota PD900: 740 mm × 320 mm × 390 mm (approx 29 in × 13 in × 15 in)
Net weight	Sarasota FD900/flanged: typically 6 kg (14 lb); Sarasota ID900/fixed flange: typically 13 kg (29 lb); Sarasota ID900/1 m stem: typically 7 kg (16 lb); Sarasota PD900: typically 5 kg (11 lb)
Environmental Rating	IP65 (NEMA 4X)
Electrical Connections	Screw terminals; Cable entry: 2 × 3/4-in NPT
Temperature Measurement	TStainless steel (316L /1.4404)
Local Display (H option)	4 1/2-digit 7.6 mm (0.3 in) 7-segment LCD display. Resolution 0.1% or 0.01% depending on display variable.
Factory Calibration Range	Depends on range selected
Operating Temperature Range	-20°C to + 60°C (-4°F to + 140°F) ambient
Process Temperature Range	-200°C to + 200°C (-328°F to + 392°F)
Maximum Operating Pressure	Sarasota FD900: 170 bar (2465 psi) or flange rating; Sarasota ID900: 150 bar (2175 psi) or flange rating; Sarasota PD900: standard stainless steel pocket: 100 bar (1450 psi); standard carbon steel pocket: 150 bar (2175 psi) quick response stainless steel pocket: 50 bar (725 psi); quick response carbon steel pocket: 50 bar (725 psi)
Output	F option (frequency output): Frequency related to density on 2-wire current modulated loop 6 mA to 18 mA; 4-wire PT100 H option (headmounted electronics): Analog 4-20 mA related to density or density derived variable; HART protocol
Power Supply	F option (frequency output): 13-28 VDC 10 mA average (peak 18 mA) H option (headmounted electronics): 2 × 13-28 VDC 25 mA
Materials	
Spool	INi-Span C or FV520B
Other Wetted Parts	Stainless steel (316L/1.4404)
Non-Wetted Parts	Stainless steel (316L/1.4404)
Electronics Housing	Copper free aluminum grey epoxy finish; Plate glass window for local display option
Pocket (Sarasota PD900 only)	Standard pocket: carbon steel ASTM A350 LF2 or stainless steel 316L/1.4404 Quick response pocket: carbon steel ASTM A350 LF2 or stainless steel 316L/1.4404
Compliance/certification	
E mark/ CE mark	ISO 9001:2000/Compliant
Electromagnetic compatibility (EN 61326:1997)	Compliant
Pressure equipment directive (97/23/EC)	SEP (sound engineering practice)
Low voltage directive	Compliant
Safe area use	Optional traceable calibration equipment listing available
BS EN ISO 15156/ NACE MR0175 Conformance	Available as option
ATEX Conformance: T6	F option (frequency output): Ex II 1 G EEx ia IIC T6 (-20°C < Ta < +60°C)
Intrinsically Safe (94/9/EC)	H option (headmounted electronics): Ex II 1 G EEx ia IIC T4 (-20°C < Ta < +60°C)
Canadian Standards Association (CSA)	Explosion-proof, Class I, Div 1, Groups B, C & D
Calibration certification	Calibration traceable to national standards. Calibration certificates supplied as standard. Optional traceable calibration equipment listing available.
Material traceability	Wetted parts traceable to BS EN 10204.3.1.b; Certification available

### USA

27 Forge Parkway  
Franklin, MA 02038  
Ph: (713) 272-0404  
Fax: (713) 272-2273  
orders.process.us@thermofisher.com

### India

C/327, TTC Industrial Area  
MIDC Pawane  
New Mumbai 400 705, India  
Ph: +91 22 4157 8800  
india@thermofisher.com

### China

+Units 702-715, 7th Floor  
Tower West, Yonghe  
Beijing, China 100007  
Ph: +86 10 84193588  
info.eid.china@thermofisher.com

### Europe

Ion Path, Road Three,  
Winsford, Cheshire CW73GA UK  
Ph: +44 1606 548700  
Fax: +44 1606 548711  
sales.epm.uk@thermofisher.com

Find out more at [thermofisher.com](http://thermofisher.com)